

2020

MotorComm

YT8511C YT8511H

Datasheet

INTEGRATED 10/100/1000 GIGABIT ETHERNET TRANSCEIVER

REV V1.09

Revision History

Revision	Release Date	Summary
0.1		Draft
1.0	2019/07/15	Update register
1.01	2019/8/1	Modify power related pins description
1.02	2019/10/09	Modify Pin description mistakes
1.03	2019/12/06	Update Register table
1.04	2019/12/24	Update LED related Register
1.05	2020/01/13	Modify Pin description Update power on sequence Update Power consumption
1.06	2020/02/13	Modify clock register ext reg 0x0c
1.07	2020/02/18	
1.08	2020/03/09	Modify the default value of extended register 0x37, 0x80, 0xb8, 0xb9, 0xba, 0xbb. Modify package information, ordering information, Add crystal/external clock requirement
1.09	2020/03/10	Official Release
1.10	2020/05/25	Modify pin 24, pin 21 name
1.11	2020/08/17	Add the RX DELAY Register description Replace the logo

CONTENT

1. General Description	8
TARGET APPLICATIONS	8
2. Feature	9
3. PIN assigment	9
QFN40 5x5mm	9
3.2 Pin Descriptions	10
MDI	11
RGMII	11
Management Interface and Interrupt	11
LED	11
System Signal Group/Reference	12
Power	12
3 Function Description	15
Application Diagram	15
1000BASE-T/100Base-Tx/10Base-Te application	15
Hyper range HR-100 4 pair application	15
Transmit Functions	16
Transmit Encoder Modes Encoder Mode Description	16
Receive Functions	16
Receive Decoder Modes	16
Hyper range	16
Echo Canceller	17
NEXT Canceller	17
Baseline Wander Canceller	17
Digital Adaptive Equalizer	17
Management interface	18

Auto-Negotiation	18
LDS (Link discovery signaling)	19
Polarity detection and auto correction	19
EEE	19
4 Operational Description	20
Reset	20
PHY Address	20
RGMII interface	21
RGMII	21
Loopback mode	21
Digital Loopback	21
External loopback	22
Remote PHY loopback	23
Master-slave configuration	23
LED	23
Auto Negotiation	24
Power Supplies	25
5 Register Overview	26
MII Management Interface Clause 22 Register Programming	26
PHY MII register	27
Phy MII 00h: Basic control register 0x00	27
Phy MII 01h: Basic status register 0x01	28
Phy MII 02h: PHY identification register1 0x02	30
Phy MII 03h: PHY identification register2 0x03	30
Phy MII 04h: Auto-Negotiation advertisement 0x04	31
Phy MII 05h: Auto-Negotiation link partner ability 0x05	35
Phy MII 06h: Auto-Negotiation expansion register 0x06	37
Phy MII 07h: Auto-Negotiation NEXT Page register 0x07	37

Phy MII 08h: Auto-Negotiation link partner Received NEXT Page register 0x08	38
Phy MII 09h: MASTER-SLAVE control register 0x09	39
Phy MII 0Ah: MASTER-SLAVE status register 0x0A	42
Phy MII 0Dh: MMD access control register 0x0D	43
Phy MII 0Eh: MMD access data register 0x0E	44
Phy MII 0Fh: Extended status register 0x0F	44
Phy MII 10h: PHY specific function control register	45
Phy MII 11h: PHY specific status register 0x11	46
Phy MII 12h: Interrupt Mask Register 0x12	48
Phy MII 13h: Interrupt Mask Register 0x13	49
Phy MII 14h: Speed Auto Downgrade Control Register 0x14	50
Phy MII 15h: Rx Error Counter Register 0x15	51
Phy MII 1Eh: Debug Register's Address Offset Register 0x1E	51
Phy MII 1Fh: Debug Register's Data Register	52
PHY EXTENDED register	53
Phy EXT 00h: MS config debug Register 0x00	53
Phy EXT 04h: Manual EEE Ability Register 0x04	53
Phy EXT 09h: 100BT Extra Test Mode Register 0x09	54
Phy EXT 0Ah: 10BT Debug, LPBKs Register 0x0A	54
Phy EXT 0Ch: Phy clock gating Register 0x0C	55
Phy EXT 0Dh: Delay and driver strength cfg Register 0x0D	56
Phy EXT 27h: Sleep Control1 0x27	58
Phy EXT 2Dh: EEE 1000BT Wake Error Timer 0x2D	58
Phy EXT 2Eh: EEE 100BT Wake Error Timer 0x2E	59
Phy EXT 30h: EEE Quite Timer Th 0x30	59
Phy EXT 34h: EEE Control2 0x34	59
Phy EXT 36h: EEE 100BT Control2 0x36	59
Phy EXT 37h: EEE 100BT Control3 0x37	60

Phy EXT 38h: pkgen cfg1 0x38	61
Phy EXT 80h: vct_cfg0 0x80	62
Phy EXT 81h: vct_cfg1 0x81	62
Phy EXT 82h: vct_cfg2 0x82	63
Phy EXT 83h: vct_cfg3 0x83	63
Phy EXT 84h: vct_mon0 0x84	64
Phy EXT 85h: vct_mon1 0x85	64
Phy EXT 86h: vct_mon2 0x86	64
Phy EXT 87h: vct_mon3 0x87	65
Phy EXT 88h: vct_mon4 0x88	65
Phy EXT 89h: vct_mon5 0x89	65
Phy EXT 8Ah: vct_mon6 0x8A	65
Phy EXT 8Bh: vct_mon7 0x8B	65
Phy EXT 8Ch: vct_mon8 0x8C	65
Phy EXT 8Dh: vct_mon9 0x8D	66
Phy EXT 8Eh: vct_monA 0x8E	66
Phy EXT 8Fh: vct_monB 0x8F	66
Phy EXT 90h: vct_monC 0x90	66
Phy EXT 91h: vct_monD 0x91	66
Phy EXT 92h: vct_monE 0x92	67
Phy EXT 93h: vct_monF 0x93	67
Phy EXT 94h: vct_mon10 0x94	67
Phy EXT 95h: vct_cfg4 0x95	67
Phy EXT 96h: vct_cfg5 0x96	68
Phy EXT 97h: vct_cfg6 0x97	68
Phy EXT 98h: vct_cfg7 0x98	68
Phy EXT 99h: vct_cfg8 0x99	68
EXT B7h: LED General Control	69

EXT B8h: LED1 Control.....	70
EXT B9h: LED2 Control	72
EXT BAh: LED Blink Control	73
EXT BBh: LED3 Control.....	74
PHY MMD1	76
Phy MMD1 00h: PMA/PMD control 1 register 0x00	76
Phy MMD1 05h: PMA/PMD devices in package 0x05.....	76
Phy MMD1 08h: PMA/PMD status 2 register 0x08.....	76
PHY MMD3	77
Phy MMD3 00h: PCS control 1 register 0x00	77
Phy MMD3 01h: PCS status 1 register 0x01	77
Phy MMD3 05h: PCS devices in package register 0x05	78
Phy MMD3 08h: PCS devices in package register 0x08	79
Phy MMD3 14h: EEE control and capability register 0x14	79
Phy MMD3 16h: EEE wake error counter 0x16.....	79
PHY MMD7	80
Phy MMD7 00h: AN Control Register 0x00.....	80
Phy MMD7 01h: AN Status Register 0x01	80
Phy MMD7 05h: AN devices in package Register 0x05	80
Phy MMD7 3Ch: Local Device EEE Ability 0x3C.....	81
Phy MMD7 3Dh: Link Partner EEE Ability 0x3D	81
6 Timing and AC Characteristics.....	83
Power ON sequence	83
RGMII Characteristics.....	83
RGMII Timing w/o delay.....	84
RGMII Timing with internal delay	85
MDIO.....	85
Crystal Requirement	86

	Oscillator/External Clock Requirement.....	86
7	Power Requirements	87
	Power Requirement.....	87
	Power consumption (Typical).....	88
8	Mechanical and Thermal	89
	RoHS-Compliant Packaging.....	89
9	Mechanical Information	90
10	Ordering Information	92

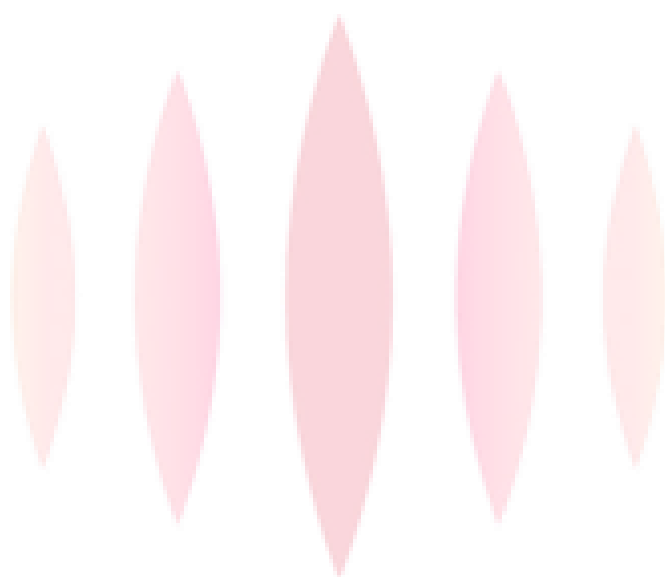

裕太车通
MotorComm

1. GENERAL DESCRIPTION

The MotorComm YT8511C YT8511H is a triple-speed 10/100/1000BASE-T Gigabit Ethernet (GbE) Ethernet physical layer transceiver (PHY). Ideally suited for a wide range of industry applications, it is manufactured using a standard digital CMOS process and contains all the active circuitry required to implement the physical layer functions to transmit and receive data on a on Category 5 unshielded twisted-pair (UTP) cabling.

Based on cutting-edge DSP technology, combining adaptive equalizers, echo canceller, phase-locked, ADCs, phase-locked loops, line drivers, encoders/decoders, echo cancelers and all other required support circuitry at a Gigabit data rate to achieve robust performance and exceed automotive electromagnetic interference (EMI) requirements in severe environments with very low power dissipation.

The YT8511C YT8511H is designed to be fully compliant with RGMII interface specifications, allowing compatibility with standard Ethernet media access controllers (MACs) and switch controllers.

The YT8511 delivers the most comprehensive technology solution required by industry operating temperature.

TARGET APPLICATIONS

- HDTV
- Gaming machines
- IP Cameras
- Printers
- LED wall

裕太车通
MotorComm

2. FEATURE

- 10BASE-T_e/100BASE-T_x/1000 BASE-T IEEE 802.3 compliant
- HYPER Range Supported, 4 pair HR-100 mode, enhance 100Mbps distance more than 400 meter
- Supports 1000 BASE-T PCS and auto-negotiation with next page support Supports RGMII interface to MAC devices with a broad I/O voltage level options 2.5V and is compatible with 3.3V I/O.
- RGMII timing modes support internal delay and external delay on Rx path
- Error-free operation up to 120 meters of CAT5e cable.
- Supports Wake-on-LAN (WoL) to detect magic packet and notify the sleeping system to wake up
- Robust Cable Discharge Event (CDE)
- Jumbo Frame support up to 10KB (full duplex)
- All digital baseline wander correction Automatic channel swap (ACS)
- Automatic MDI/MDIX crossover
- Automatic polarity correction
- IEEE 802.3u compliant Auto-Negotiation
- Software programmable LED modes
- Multiple Loopback modes for diagnostics

裕太车通
MotorComm

3. PIN ASSIGNMENT

QFN40 5X5MM

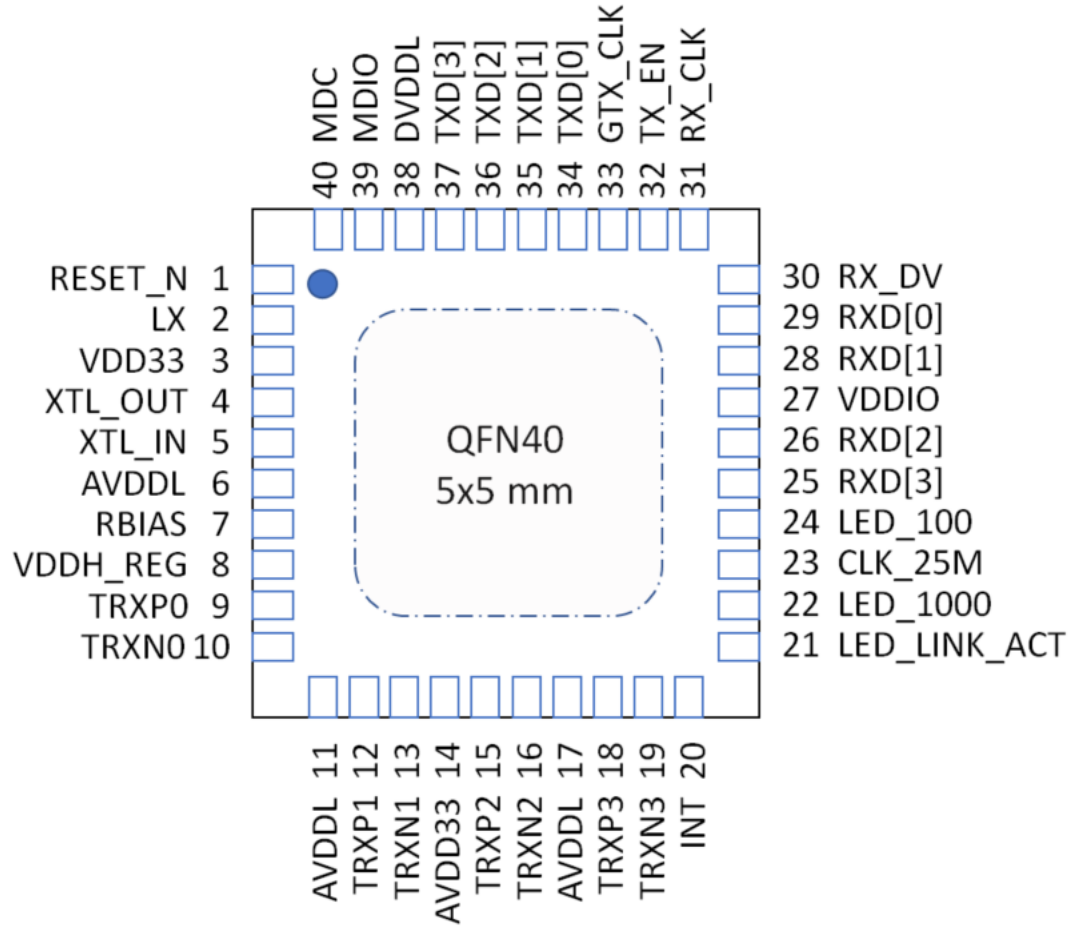

裕太车通
MotorComm

3.2 PIN DESCRIPTIONS

- I = Input
- O = Output
- I/O = Bidirectional
- OD = Open-drain output
- OT = Tristateable signal
- B = Bias
- PU = Internal pull-up
- PD = Internal pull-down
- SOR = Sample on reset
- CS = Continuously sampled
- ST = Schmitt trigger
- XT = Crystal inputs/outputs pin type
- D = Digital pin type
- G = RGMII pin type
- A = Analog pin type



裕太车通
MotorComm

Symbol	Pin	Type	Description
MDI			
TRXP0, TRXN0	9 10	IA, OA	Media-dependent interface 0, 100Ω transmission line
TRXP1, TRXN1	12, 13	IA, OA	Media-dependent interface 1, 100Ω transmission line
TRXP2, TRXN2	15, 16	IA, OA	Media-dependent interface 2, 100Ω transmission line
TRXP3, TRXN3	18, 19	IA, OA	Media-dependent interface 3, 100Ω transmission line
RGMII			
GTX_CLK	33	I, PD	RGMII transmit clock, 125/25/2.5 MHz digital. Adding a 22ohm damping resistor is recommended for EMI design near MAC side.
RX_CLK	31	I/O, PD	125MHz digital, adding a 22ohm damping resistor is recommended for EMI design near PHY side.
RX_DV	30	I/O, PD	RGMII receive data valid
RXD[0]	29	I/O, PD	RGMII received data 0
RXD[1]	28	I/O, PD	RGMII received data 1
RXD[2]	26	I/O, PD	RGMII received data 2
RXD[3]	25	I/O, PD	RGMII received data 3
TX_EN	32	I, PD	RGMII transmit enable
TXD[0]	34	I, PD	RGMII transmit data 0
TXD[1]	35	I, PD	RGMII transmit data 1
TXD[2]	36	I, PD	RGMII transmit data 2
TXD[3]	37	I, PD	RGMII transmit data 3
MANAGEMENT INTERFACE AND INTERRUPT			
MDC	40	I, PU	Management data clock reference
MDIO	39	I/O, D, PU	Management data, pull-up resistor to 3.3V/2.5V
INT	20	I/O, D, PD	Interrupt Signal to System; default OD-gate, needs an external pull up resistor
LED			

LED_LINK_AC T	21	I/O, PU	Parallel LED output for 10/100/1000 BASE-T link and activity , active blinking. LED active based upon power-on strapping. If pulled up, active low, if pulled down, active high
LED_1000	22	I/O, PU	Parallel LED output for 1000 BASE-T link, LED active based upon power-on strapping.
LED_100	24	I/O, PU	Parallel LED output for 100 BASE-T link.
SYSTEM SIGNAL GROUP/REFERENCE			
CLK_25M	23	O, PD	25 MHz clock output (default). It can be 125, 62.5 or 25 MHz clock output
RESET_N	1	I	System reset, active low. Requires an external pull-up resistor
XTLI	5	IA	Crystal oscillator input. Requires a capacitor to GND. <u>If use external oscillator or clock from another device.</u> 1. When an external 25Hhz oscillator or clock from another device drivers XTAL_OUT. XTAL_IN must be shorted to GND(suggested) 2. When an external 25Hhz oscillator or clock from another device drivers XTAL_IN; keep the XTAL_OUT floating.
XTLO	4	OA	Crystal oscillator output; add a capacitor to GND. <u>If use external oscillator or clock from another device.</u> 1. When an external 25Hhz oscillator or clock from another device drivers XTAL_OUT. XTAL_IN must be shorted to GND(suggested) 2. When an external 25Hhz oscillator or clock from another device drivers XTAL_IN; keep the XTAL_OUT floating.
RBIAS	7	OA	External 2.4 k ohm 1% to GND to set bias current
POWER			
LX	2	OA	Power inductor pin. Add an external 4.7 uH power inductor between this pin and pin 38.
VDDH_REG	8	OA	3.3V or 2.5 V regulator output. A 1uF capacitor connected to GND.
VDDIO	27	IA	VDDIO input. Connect this pin to pin 8 (VDDH_REG) directly.
AVDDL	6, 11 17	P	1.2 V analog power input. Connect to Pin 38 through a bead
DVDDL	38	P	1.2 V digital core power input. Connect to power inductor and 10uF+0.1uF ceramic capacitors to GND
VDD33	3	P	3.3 V power for switching regulator
AVDD33	14	P	Analog 3.3 V power input for PHY, from VDD33 through a bead

EPAD	-	Exposed ground pad on back of the chip, tie to ground
------	---	---

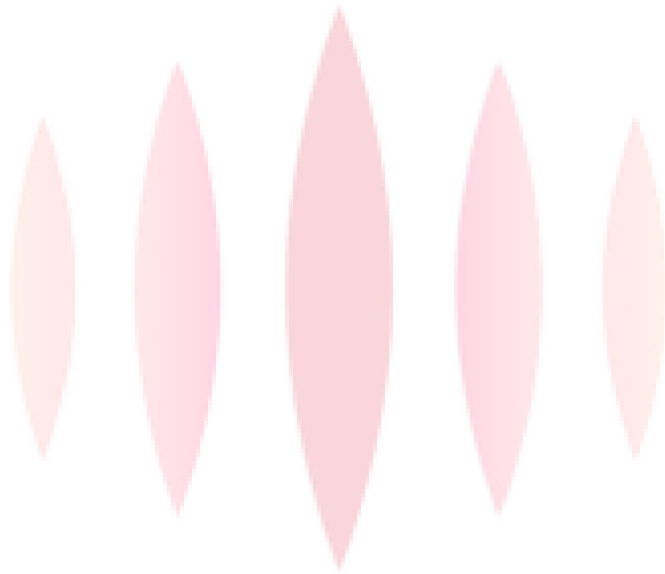

裕太车通
MotorComm

POWER ON STRAPPING

PHY Pin	PHY Core Config	Description	Default
RXD0	PHYADDRESS0	LED_ACT, RXD[1:0] sets the lower three bits of the physical address. The upper two bits of the physical address are set to the default, "00"	0
RXD1	PHYADDRESS1	LED_ACT, RXD[1:0] sets the lower three bits of the physical address. The upper two bits of the physical address are set to the default, "00"	0
LED_ACT	PHYADDRESS2	LED_ACT, RXD[1:0] sets the lower three bits of the physical address. The upper two bits of the physical address are set to the default, "00"	1
RX_DV	RGMII IO power selection	0= RGMII IO 3.3V 1= RGMII IO 2.5V	0
RXD2	PLLON selection	0= PLL off in hibernation when cable unplugged 1= PLL on in hibernation when cable unplugged	0
LED_1000	TEST Mode	0=Test Mode only for internal use 1=Normal Mode, Must external pull up	1
RXD3	Low Power Mode selection	0= Force Low Power mode for shorter cable application 1= Normal cable application	0
LED_10_100	RXC delay enable	0= RXC delay disable 1= RXC delay enable	1
RX_CLK	clk 25m disable	0= clk 25m output enable 1= clk 25m output disable	0

NOTE: 0=Pull-down, 1=Pull-up

裕太车通
MotorComm

3 FUNCTION DESCRIPTION

The YT8511 is MotorComm low cost GbE PHY. It is a highly integrated analog front end (AFE) and digital signal transceiver, providing high performance combined with substantial cost reduction. The YT8511 provides physical layer functions for half/full duplex 10 BASE-Te, 100 BASE-Tx and 1000 BASE-T Ethernet to transmit and receive high-speed data over standard category 5 (CAT5) unshielded twisted pair cable.

The YT8511 10/100/1000 PHY is fully 802.3ab compliant, and supports the reduced Gigabit Media-Independent Interface (RGMI) to connect to a Gigabit-capable MAC.

The YT8511 transceiver combines echo canceller, near end cross talk (NEXT) canceller, feed-forward equalizer, feedback equalizer, and timing recovery, to enhance signal performance in noisy environments.

APPLICATION DIAGRAM

1000BASE-T/100BASE-TX/10BASE-TE APPLICATION

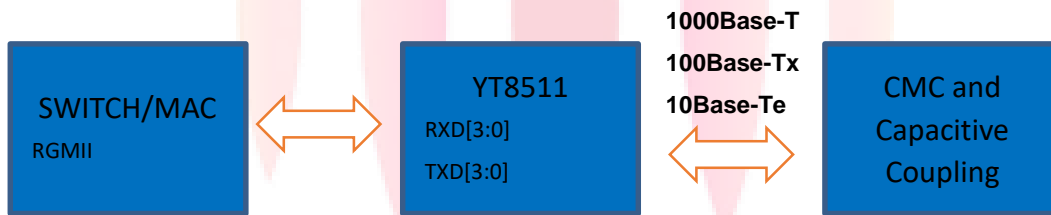

HYPER RANGE HR-100 4 PAIR APPLICATION

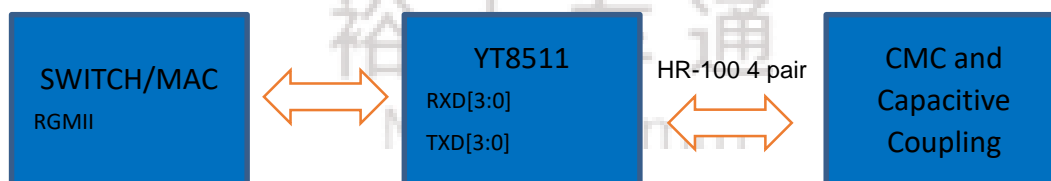

TRANSMIT FUNCTIONS

TRANSMIT ENCODER MODES ENCODER MODE DESCRIPTION

1000 BASE-T

In 1000 BASE-T mode, the YT8511 scrambles transmit data bytes from the MAC interfaces to 8-bit symbols and encodes them into 4D five-level PAM signals over the four pairs of CAT5 cable.

100 BASE-TX

In 100 BASE-TX mode, 4-bit data from the MII is 4B/5B serialized, scrambled, and encoded to a three-level MLT3 sequence transmitted by the PMA.

10 BASE-TE

In 10 BASE-Te mode, the YT8511 transmits and receives Manchester-encoded data.

RECEIVE FUNCTIONS

RECEIVE DECODER MODES

1000 BASE-T

In 1000 BASE-T mode, the PMA recovers the 4D PAM signals after accounting for the cabling conditions such as skew among the four pairs, the pair swap order, and the polarity of the pairs. The resulting code group is decoded into 8-bit data values. Data stream delimiters are translated appropriately and data is output to the MAC interfaces.

100 BASE-TX

IN 100 BASE-TX MODE, THE RECEIVE

data stream is recovered and descrambled to align to the symbol boundaries. The aligned data is then parallelized and 5B/ 4B decoded to 4-bit data. This output runs to the MII receive data pins after data stream delimiters have been translated.

10 BASE-TE

In 10 BASE-Te mode, the recovered 10 BASE-Te signal is decoded from Manchester then aligned.

HYPER RANGE

Hyper-range is the motor-comm proprietary mode in extended cable reach application up to 400m in 100M mode. HR-100 is 100Mbps Mode.

ECHO CANCELLER

A hybrid circuit is used to transmit and receive simultaneously on each pair. A signal reflects back as an echo if the transmitter is not perfectly matched to the line. Other connector or cable imperfections, such as patch panel discontinuity and variations in cable impedance along the twisted pair cable, also result in drastic SNR degradation on the receive signal. The YT8511 device implements a digital echo canceller to adjust for echo and is adaptive to compensate for the varied channel conditions.

NEXT CANCELLER

The 1000 BASE-T physical layer uses all four pairs of wires to transmit data. Because the four twisted pairs are bundled together, significant high frequency crosstalk occurs between adjacent pairs in the bundle. The YT8511 device uses three parallel NEXT cancellers on each receive channel to cancel high frequency crosstalk. The YT8511 cancels NEXT by subtracting an estimate of these signals from the equalizer output.

BASELINE WANDER CANCELLER

Baseline wander results from Ethernet links that AC-couple to the transceivers and from AC coupling that cannot maintain voltage levels for longer than a short time. As a result, transmitted pulses are distorted, resulting in erroneous sampled values for affected pulses. Baseline wander is more problematic in the 1000 BASE-T environment than in 100 BASE-TX due to the DC baseline shift in the transmit and receive signals. The YT8511 device uses an advanced baseline wander cancellation circuit that continuously monitors and compensates for this effect, minimizing the impact of DC baseline shift on the overall error rate.

DIGITAL ADAPTIVE EQUALIZER

The digital adaptive equalizer removes inter-symbol interference at the receiver. The digital adaptive equalizer takes unequalized signals from ADC output and uses a combination of feedforward equalizer (FFE) and decision feedback equalizer (DFE) for the best optimized signal-to-noise (SNR) ratio.

MANAGEMENT INTERFACE

The Status and Control registers of the device are accessible through the MDIO and MDC serial interface. The functional and electrical properties of this management interface comply with IEEE 802.3, Section 22 and also support MDC clock rates up to 12.5 MHz.

AUTO-NEGOTIATION

The YT8511 negotiates its operation mode using the auto negotiation mechanism according to IEEE 802.3 clause 28 over the copper media. Auto negotiation supports choosing the mode of operation automatically by comparing its own abilities and received abilities from link partner. The advertised abilities include:

- a) Speed: 10/100/1000Mbps
- b) Duplex mode: full duplex and/or half duplex

Auto negotiation is initialized when the following scenarios happen:

- a) Power-up/Hardware/Software reset
- b) Auto negotiation restart
- c) Transition from power-down to power up
- d) Link down

Auto negotiation is enabled for YT8511 by default, and can be disabled by software control.

裕太车通
MotorComm

LDS (LINK DISCOVERY SIGNALING)

YT8511 supports long range ethernet (LRE), which uses link discovery signaling (LDS) instead of auto negotiation since the extended cable reach attenuates the auto negotiation link pulses. LDS is an extended reach signaling scheme and protocol, which is used to

- a) Master/Slave assignment
- b) Estimate cable length
- c) Confirm pair number and pair connectivity ordering
- d) Choose highest common operation mode

IEEE-compliant PHYs will ignore LDS signal since its frequency is less than 2MHz according to IEEE802.3 clause 14. If the link partner is an IEEE legacy ethernet PHY, YT8511 can detect the standard NLP, FLP, MLT-3 IDLE signal, or 100BASE-T4 signal, and then transits LDS mode into Clause 28 auto negotiation mode.

Forcing pair number and speed mode is also supported. The same forcing must be done at both ends of the link.

POLARITY DETECTION AND AUTO CORRECTION

YT8511 can detect and correct two types of cable errors: swapping of pairs within the UTP cable and swapping of wires within a pair.

EEE

EEE is IEEE 802.3az, an extension of the IEEE 802.3 standard. EEE defines support for the PHY to operate in Low Power Idle (LPI) mode which, when enabled, supports QUIET times during low link utilization allowing both link partners to disable portions of each PHY's circuitry and save power.

4 OPERATIONAL DESCRIPTION

RESET

YT8511 have a hardware reset pin(RESET_N) which is low active. RESET_N should be active for at least 10ms to make sure all internal logic is reset to a known state. Hardware reset should be applied after power up.

RESET_N is also used as enable for power on strapping. After RESET_N is released, YT8511 latches input value on strapping pin which is used as configuration information which provides flexibility in application without mdio access. Detailed information please refer to pin description in table x(index for table and figure).

YT8511 also provides two software reset control registers which are used to reset all internal logic except some mdio configuration registers. For detailed information about what register will be reset by software reset, please refer to register table. Configure bit 15 of lds mii register(address 0x0) or mii register(address 0x0) to 1 to enable software reset. These two bits are self-clear after reset process is done.

PHY ADDRESS

For YT8511, {LED_ACT, RXD[1:0]} is used to generate lower 3 bits of phy address. The upper 2 bits are always 0. So valid phy address is from 5'b00000 to 5'b00111.

YT8511 always response to phy address 0. Bit[6] of extended register(address 0x0) is enable control for phy address 0 and its default value is 1'b1. It also has another broadcast phy address which is configurable through mdio. Bit[4:0] of extended register(address 0x0) is broadcast phy address and its default value is 5'b11111. Bit[5] of extended register(address 0x0) is enable control for broadcast phy address and its default value is 1'b1.

PHY Pin	PHY Core Config	Description	Default
RXD0	PHYADDRESS0	LED_ACT, RXD[1:0] sets the lower three bits of the physical address. The upper two bits of the physical address are set to the default, "00"	0
RXD1	PHYADDRESS1	LED_ACT, RXD[1:0] sets the lower three bits of the physical address. The upper two bits of the physical address are set to the default, "00"	0
LED_ACT	PHYADDRESS2	LED_ACT, RXD[1:0] sets the lower three bits of the physical address. The upper two bits of the physical address are set to the default, "00"	1

RGMII INTERFACE

RGMII

Reduced gigabit media independent interface is a subset of GMII which is used for gigabit Ethernet. For 100M/10M application, RGMII is similar to MII. The only difference is that tx_er/rx_er is transmitted by tx_en/rx_dv on the falling edge of clock. TXD[3:0] and RXD[3:0] will be duplicated on both rising and falling edge of clock. For 100M application, TXC and RXC are 25MHz; for 10M application, TXC and RXC are 2.5MHz.

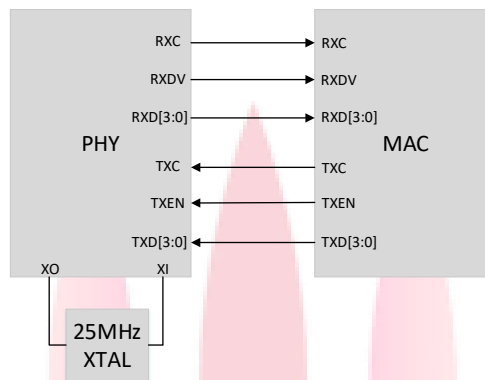

Figure . connection diagram of RGMII

LOOPBACK MODE

There are three loopback modes in YT8511.

DIGITAL LOOPBACK

Digital loopback provides the ability to loop transmitted data back to the receiver using digital circuitry in the YT8511 device.

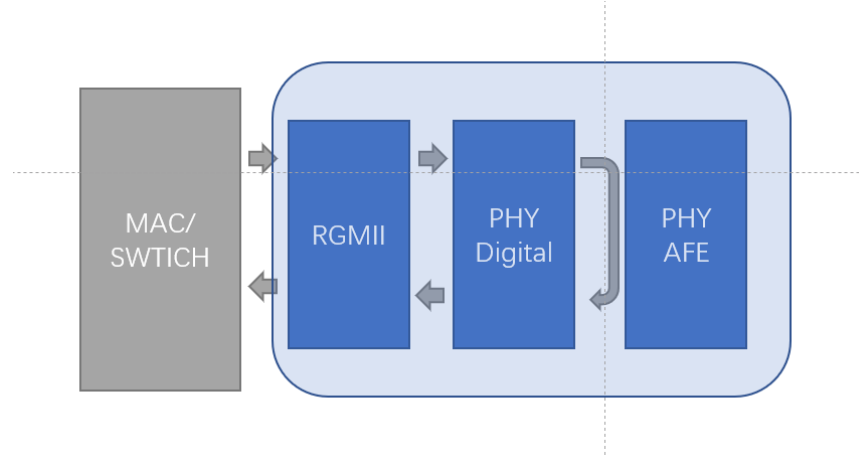

Figure . digital loopback

1000M loopback: write register 0x0 = 0x4140 to enable 1000M digital loopback.

100M loopback: write register 0x0 = 0x6100 to enable 100M digital loopback.

10M loopback: write register 0x0 = 0x4100 to enable 10M digital loopback.

EXTERNAL LOOPBACK

External cable loopback loops Tx to Rx through a complete digital and analog path and an external cable, thus testing all the digital data paths and all the analog circuits. Figure shows a block diagram of external cable loopback.

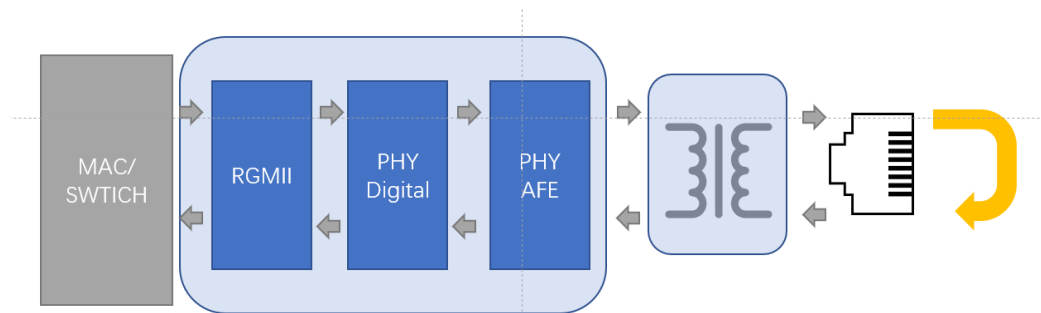
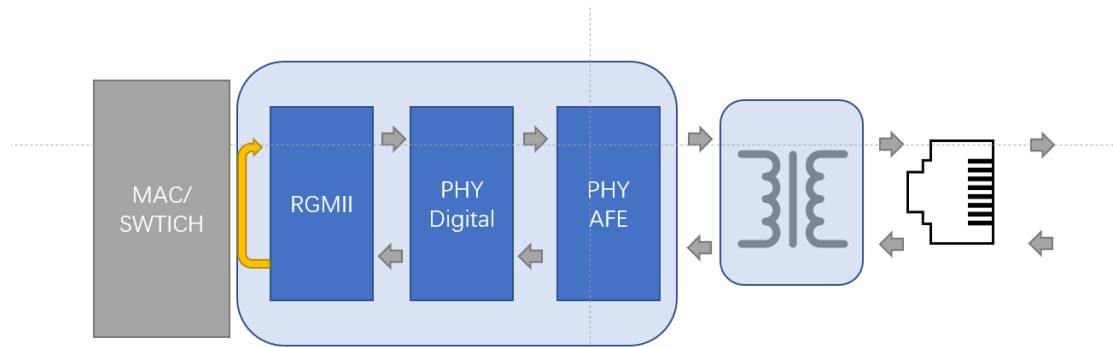

Figure . external loopback

裕太车通
MotorComm

REMOTE PHY LOOPBACK

The Remote loopback connects the MDI receive path to the MDI transmit path, near the RGMII interface, thus the remote link partner can detect the connectivity in the resulting loop. Figure below, shows the path of the remote loopback.



MASTER-SLAVE CONFIGURATION

Master and slave configuration only exist in HR-100 mode.

Master and slave configuration is from lds negotiating result or in force mode, it comes from bit 3 of lds mii reg(address 0h0).

LED

The LED interface can either be controlled by the PHY or controlled manually, independent of the state of the PHY. Three status LEDs are available. These can be used to indicate operation speed, duplex mode, and link status. The LEDs can be programmed to different status functions from their default value. They can also be controlled directly from the register interface.

Symbol	10M link	10M active	100M link	100M active	1000M link	1000M active
LED_100	off	off	on	on	off	off
LED_1000	off	off	off	off	on	on
LED_LINK_ACT	on	blink	on	blink	on	blink

AUTO NEGOTIATION

When auto negotiation is enabled, YT8511 operation mode is based on the negotiation results, including speed and duplex mode. Registers configurations are shown as:

Register Type	Register Address	Write Value	Comments
Extended	16'h0100	16'h0006	Bit2: 1'b1, Access IEEE MII regs
MII	16'h0000		Bit12: 1'b1, enable auto negotiation

Table: Enable auto negotiation

Register Type	Register Address	Write Value	Comments
Extended	16'h0100	16'h0006	Bit2: 1'b1, Access IEEE MII regs
MII	16'h0000		Bit9: 1'b1, restart auto negotiation

Table: Restart auto negotiation

Register Type	Register Address	Write Value	Comments
Extended	16'h0100	16'h0006	Bit2: 1'b1, Access IEEE MII regs
MII	16'h0001		Bit5: 1'b1, AN complete; 1'b0, AN not complete Bit3: 1'b1, support AN; 1'b0, not support AN Bit2: 1'b1, Link up; 1'b0, link down
MII	16'h0011		Bit15-14: 2'b00, 10Mbps; 2'b01: 100Mbps Bit5: 1'b1, link is downgrade; 1'b0, link is not downgrade

Table: Auto negotiation status

When auto negotiation is disabled, forcing speed and duplex mode is also support. Forcing 10BASE-T has been discussed in the LDS part. Registers configuration for Forcing 100BASE-TX is shown as:

Register Type	Register Address	Write Value	Comments
Extended	16'h0100	16'h0006	Bit2: 1'b1, Access IEEE MII regs
MII	16'h0000		Bit12: 1'b0, disable auto negotiation Bit6,13: 2'b01, 100Mbps Bit8: 1'b1, full duplex

Table: Forcing 100BASE-TX

During auto negotiation, YT8511 supports automatic MDI crossover by detecting and correcting external crossover cable. If the link partner also supports automatic MDI crossover, only one device performs the crossover according to IEEE 802.3 Clause 40.4.4. YT8511 also supports forcing MDI/MDIX mode. Registers configurations are shown as:

Register Type	Register Address	Write Value	Comments
Extended	16'h0100	16'h0006	Bit2: 1'b1, Access IEEE MII regs
MII	16'h0010		Bit6-5: 2'b00, forcing MDI; 2'b01, forcing MDIX; 2'b11, automatic MDI crossover

Table: MDI/MDI-X configuration

POWER SUPPLIES

The YT8511 device requires only one external power supply: 3.3 V. Inside the chip there is a 3.3V rail, 2.5V rail, 1.2V rail.

YT8511 integrates a switch regulator which converts 3.3V to 1.2V at a high-efficiency for core power rail. (It is optional for an external regulator to provide this core voltage).

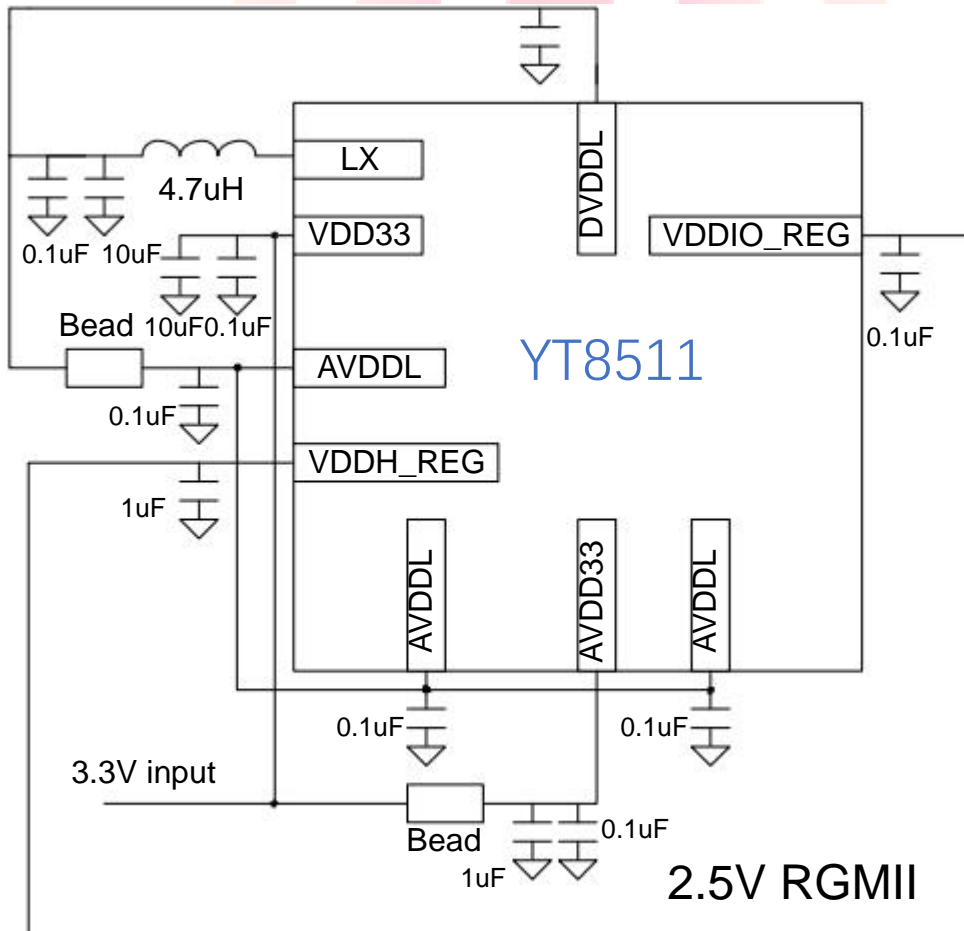

5 REGISTER OVERVIEW

MII MANAGEMENT INTERFACE CLAUSE 22 REGISTER PROGRAMMING

The YT8511 transceiver is designed to be fully compliant with the MII clause of the IEEE 802.3u Ethernet specification.

The MII management interface registers are written and read serially, using the MDIO and MDC pins.

A clock of up to 25 MHz must drive the MDC pin of the YT8511. Data transferred to and from the MDIO pin is synchronized with the MDC clock. The following sections describe what each MII read or write instruction contains.

Notation	Description
RW	Read and write
SC	Self-clear
RO	Read only
LH	Latch high
LL	Latch low
RC	Read clear
SWC	Clear to 0 when software reset
SWS	Set to 1 when software reset
CRW	Read and conditionally Write
POS	Power On Strapping

PHY MII REGISTER

PHY MII 00H: BASIC CONTROL REGISTER 0X00				
Bit	Symbol	Access	Default	Description
15	Reset	RW SC	0x0	PHY Software Reset. Writing 1 to this bit causes immediate PHY reset. Once the operation is done, this bit is cleared automatically. 0: Normal operation 1: PHY reset
14	Loopback	RW SWC	0x0	Internal loopback control 1'b0: disable loopback 1'b1: enable loopback
13	Speed_Selection(LSB)	RW	0x0	LSB of speed_selection[1:0]. Link speed can be selected via either the Auto-Negotiation process, or manual speed selection speed_selection[1:0]. Speed_selection[1:0] is valid when Auto-Negotiation is disabled by clearing bit 0.12 to zero. Bit6 bit13 1 1 = Reserved 1 0 = 1000Mb/s 0 1 = 100Mb/s 0 0 = 10Mb/s
12	Autoneg_En	RW	0x1	1: to enable auto-negotiation; 0: auto-negotiation is disabled.
11	Power_down	RW SWC	0x0	1 = Power down 0 = Normal operation When the port is switched from power down to normal operation, software reset and Auto-Negotiation are performed even

				bit[15] RESET and bit[9] RESTART_AUTO_NEGOTIATION are not set by the user.
10	Isolate	RW SWC	0x0	Isolate phy from RGMII/SGMII/FIBER. 1'b0: Normal mode 1'b1: Isolate mode
9	Re_Autoneg	RW SC SWS	0x0	Auto-Negotiation automatically restarts after hardware or software reset regardless of bit[9] RESTART. 1 = Restart Auto-Negotiation Process 0 = Normal operation
8	Duplex_Mode	RW	0x1	The duplex mode can be selected via either the Auto-Negotiation process or manual duplex selection. Manual duplex selection is allowed when Auto-Negotiation is disabled by setting bit[12] AUTO_NEGOTIATION to 0. 1 = Full Duplex 0 = Half Duplex
7	Collision_Test	RW SWC	0x0	Setting this bit to 1 makes the COL signal asserted whenever the TX_EN signal is asserted. 1 = Enable COL signal test 0 = Disable COL signal test
6	Speed_Selection(MSB)	RW	0x1	See bit13.
5:0	Reserved	RO	0x0	Reserved. Write as 0, ignore on read
PHY MII 01H: BASIC STATUS REGISTER 0X01				

Bit	Symbol	Access	Default	Description
15	100Base-T4	RO	0x0	PHY doesn't support 100BASE-T4
14	100Base-X_Fd	RO	0x1	PHY supports 100BASE-X_FD
13	100Base-X_Hd	RO	0x1	PHY supports 100BASE-X_HD
12	10Mbps_Fd	RO	0x1	PHY supports 10Mbps_Fd
11	10Mbps_Hd	RO	0x1	PHY supports 10Mbps_Hd
10	100Base-T2_Fd	RO	0x0	PHY doesn't support 100Base-T2_Fd
9	100Base-T2_Hd	RO	0x0	PHY doesn't support 100Base-T2_Hd
8	Extended_Status	RO	0x1	Whether support EXTended status register in 0Fh 0: Not supported 1: Supported
7	Unidirect_Ability	RO	0x0	1'b0: PHY able to transmit from MII only when the PHY has determined that a valid link has been established 1'b1: PHY able to transmit from MII regardless of whether the PHY has determined that a valid link has been established
6	Mf_Preamble_Suppression	RO	0x1	1'b0: PHY will not accept management frames with preamble suppressed 1'b1: PHY will accept management frames with preamble suppressed
5	Autoneg_Complete	RO SWC	0x0	1'b0: Auto-negotiation process not completed 1'b1: Auto-negotiation process completed

4	Remote_Fault	RO RC SWC LH	0x0	1'b0: no remote fault condition detected 1'b1: remote fault condition detected
3	Autoneg_Ability	RO	0x1	1'b0: PHY not able to perform Auto-negotiation 1'b1: PHY able to perform Auto-negotiation
2	Link_Status	RO SWC LL	0x0	Link status 1'b0: Link is down 1'b1: Link is up
1	Jabber_Detect	RO RC SWC LH	0x0	10Baset jabber detected. It would assert if TX activity lasts longer than 42ms. 1'b0: no jabber condition detected 1'b1: Jabber condition detected.
0	Extended_Capability	RO	0x1	To indicate whether support EXTended registers, to access from address register 1Eh and data register 1Fh 1'b0: Not supported 1'b1: Supported

 PHY MII 02H: PHY IDENTIFICATION REGISTER1 0X02

Bit	Symbol	Access	Default	Description
15:0	Phy_Id	RO	0x0	Bits 3 to 18 of the Organizationally Unique Identifier

 PHY MII 03H: PHY IDENTIFICATION REGISTER2 0X03

Bit	Symbol	Access	Default	Description
15:10	Phy_Id	RO	0x0	Bits 19 to 24 of the Organizationally Unique Identifier
9:4	Type_No	RO	0x10	6 bits manufacturer's type number

3:0	Revision_No	RO	0xa	4 bits manufacturer's revision number
PHY MII 04H: AUTO-NEGOTIATION ADVERTISEMENT 0X04				
Bit	Symbol	Access	Default	Description
15	NEXT_Page	RW	0x0	<p>This bit is updated immediately after the writing operation; however the configuration does not take effect until any of the following occurs:</p> <ul style="list-style-type: none"> • Software reset is asserted by writing register 0x0 bit[15] • Restart Auto-Negotiation is triggered by writing register 0x0 bit[9] • The port is switched from power down to normal operation by writing register 0x0 bit[11] • Link goes down <p>If 1000BASE-T is advertised, the required next pages are automatically transmitted. This bit must be set to 0 if no additional next page is needed.</p> <p>1 = Advertise 0 = Not advertised</p>
14	Ack	RO	0x0	Always 0.
13	Remote_Fault	RW	0x0	<p>1 = Set Remote Fault bit 0 = Do not set Remote Fault bit</p>
12	Extended_NEXT_Page	RW	0x1	<p>Extended nEXT page enable control bit</p> <p>1 = Local device supports transmission of extended next pages</p>

				0 = Local device does not support transmission of extended next pages.
11	Asymmetric_Pause	RW	0x1	<p>This bit is updated immediately after the writing operation; however the configuration does not take effect until any of the following occurs:</p> <ul style="list-style-type: none"> • Software reset is asserted by writing register 0x0 bit[15] • Restart Auto-Negotiation is triggered by writing register 0x0 bit[9] • The port is switched from power down to normal operation by writing register 0x0 bit[11] • Link goes down <p>1 = Asymmetric Pause 0 = No asymmetric Pause</p>
10	Pause	RW	0x1	<p>This bit is updated immediately after the writing operation; however the configuration does not take effect until any of the following occurs:</p> <ul style="list-style-type: none"> • Software reset is asserted by writing register 0x0 bit[15] • Restart Auto-Negotiation is triggered by writing register 0x0 bit[9] • The port is switched from power down to normal operation by writing register 0x0 bit[11] • Link goes down <p>1 = MAC PAUSE implemented 0 = MAC PAUSE not implemented</p>

9	100BASE-T4	RO	0x0	<p>1 = Able to perform 100BASE-T4</p> <p>0 = Not able to perform 100BASE-T4</p> <p>Always 0</p>
8	100BASE-TX_Full_Duplex	RW	0x1	<p>This bit is updated immediately after the writing operation; however the configuration does not take effect until any of the following occurs:</p> <ul style="list-style-type: none"> • Software reset is asserted by writing register 0x0 bit[15] • Restart Auto-Negotiation is triggered by writing register 0x0 bit[9] • The port is switched from power down to normal operation by writing register 0x0 bit[11] • Link goes down <p>1 = Advertise</p> <p>0 = Not advertised</p>
7	100BASE-TX_Half_Duplex	RW	0x1	<p>This bit is updated immediately after the writing operation; however the configuration does not take effect until any of the following occurs:</p> <p>This bit is updated immediately after the writing operation; however the configuration does not take effect until any of the following occurs:</p> <ul style="list-style-type: none"> • Software reset is asserted by writing register 0x0 bit[15] • Restart Auto-Negotiation is triggered by writing register 0x0 bit[9] • The port is switched from power down to normal operation by

				<p>writing register 0x0 bit[11]</p> <ul style="list-style-type: none"> • Link goes down <p>1 = Advertise 0 = Not advertised</p>
6	10BASE- Te_Full_Duplex	RW	0x1	<p>This bit is updated immediately after the writing operation; however the configuration does not take effect until any of the following occurs:</p> <ul style="list-style-type: none"> • Software reset is asserted by writing register 0x0 bit[15] • Restart Auto-Negotiation is triggered by writing register 0x0 bit[9] • The port is switched from power down to normal operation by writing register 0x0 bit[11] • Link goes down <p>1 = Advertise 0 = Not advertised</p>
5	10BASE- Te_Half_Duplex	RW	0x1	<p>This bit is updated immediately after the writing operation; however the configuration does not take effect until any of the following occurs:</p> <ul style="list-style-type: none"> • Software reset is asserted by writing register 0x0 bit[15] • Restart Auto-Negotiation is triggered by writing register 0x0 bit[9] • The port is switched from power down to normal operation by writing register 0x0 bit[11]

				<ul style="list-style-type: none"> Link goes down 1 = Advertise 0 = Not advertised
4:0	Selector_Field	RW	0x1	Selector Field mode. 00001 = IEEE 802.3
PHY MII 05H: AUTO-NEGOTIATION LINK PARTNER ABILITY 0X05				
Bit	Symbol	Access	Default	Description
15	1000Base-X_Fd	RO SWC	0x0	Received Code Word Bit 15 1 = Link partner is capable of next page 0 = Link partner is not capable of next page
14	ACK	RO SWC	0x0	Acknowledge. Received Code Word Bit 14 1 = Link partner has received link code word 0 = Link partner has not received link code word
13	REMOTE_FAULT	RO SWC	0x0	Remote Fault. Received Code Word Bit 13 1 = Link partner has detected remote fault 0 = Link partner has not detected remote fault
12	RESERVED	RO SWC	0x0	Technology Ability Field. Received Code Word Bit 12
11	ASYMMETRIC_PAUSE	RO SWC	0x0	Technology Ability Field. Received Code Word Bit 11 1 = Link partner requests asymmetric pause 0 = Link partner does not request

				asymmetric pause
10	PAUSE	RO SWC	0x0	Technology Ability Field. Received Code Word Bit 10 1 = Link partner supports pause operation 0 = Link partner does not support pause operation
9	100BASE-T4	RO SWC	0x0	Technology Ability Field. Received Code Word Bit 9 1 = Link partner supports 100BASE-T4 0 = Link partner does not support100BASE-T4
8	100BASE- TX_FULL_DUPLEX	RO SWC	0x0	Technology Ability Field. Received Code Word Bit 8 1 = Link partner supports 100BASE-TX full-duplex 0 = Link partner does not support 100BASE-TX full-duplex
7	100BASE- TX_HALF_DUPLEX	RO SWC	0x0	Technology Ability Field. Received Code Word Bit 7 1 = Link partner supports 100BASE-TX half-duplex 0 = Link partner does not support 100BASE-TX half-duplex
6	10BASE- Te_FULL_DUPLEX	RO SWC	0x0	Technology Ability Field. Received Code Word Bit 6 1 = Link partner supports 10BASE-Te full-duplex 0 = Link partner does not support 10BASE-Te full-duplex

5	10BASE- Te_HALF_DUPLEX	RO SWC	0x0	Technology Ability Field. Received Code Word Bit 5 1 = Link partner supports 10BASE-Te half-duplex 0 = Link partner does not support 10BASE-Te half-duplex
4:0	SELECTOR_FIELD	RO SWC	0x0	Selector Field Received Code Word Bit 4:0
PHY MII 06H: AUTO-NEGOTIATION EXPANSION REGISTER 0X06				
Bit	Symbol	Access	Default	Description
15:5	Reserved	RO	0x0	Reserved
4	Parallel Detection fault	RO RC SWC LH	0x0	1 = Fault is detected 0 = No fault is detected
3	Link partner nEXT page able	RO SWC LH	0x0	1 = Link partner supports NEXT page 0 = Link partner does not support next page
2	Local NEXT Page able	RO	0x1	1 = Local Device supports NEXT Page 0 = Local Device does not Next Page
1	Page received	RO RC LH	0x0	1 = A new page is received 0 = No new page is received
0	Link Partner Auto negotiation able	RO	0x0	1 = Link partner supports auto- negotiation 0 = Link partner does not support auto-negotiation
PHY MII 07H: AUTO-NEGOTIATION NEXT PAGE REGISTER 0X07				
Bit	Symbol	Access	Default	Description

15	NEXT Page	RW	0x0	Transmit Code Word Bit 15 1 = The page is not the last page 0 = The page is the last page
14	Reserved	RO	0x0	Transmit Code Word Bit 14
13	Message page mode	RW	0x1	Transmit Code Word Bit 13 1 = Message Page 0 = Unformatted Page
12	Ack2	RW	0x0	Transmit Code Word Bit 12 1 = Comply with message 0 = Cannot comply with message
11	Toggle	RO	0x0	Transmit Code Word Bit 11 1 = This bit in the previously exchanged Code Word is logic 0 0 = The Toggle bit in the previously exchanged Code Word is logic 1
10:0	Message/Unformatted	RW	0x1	Transmit Code Word Bits [10:0]. These bits are encoded as Message Code Field when bit[13] is set to 1, or as Unformatted Code Field when bit[13] is set to 0.

PHY MII 08H: AUTO-NEGOTIATION LINK PARTNER RECEIVED NEXT PAGE REGISTER 0X08

Bit	Symbol	Access	Default	Description
15	NEXT Page	RO	0x0	Received Code Word Bit 15 1 = This page is not the last page 0 = This page is the last page
14	Reserved	RO	0x0	Received Code Word Bit 14
13	Message page mode	RO	0x0	Received Code Word Bit 13 1 = Message Page 0 = Unformatted Page

12	Ack2	RO	0x0	Received Code Word Bit 12 1 = Comply with message 0 = Cannot comply with message
11	Toggle	RO	0x0	Received Code Word Bit 11 1 = This bit in the previously exchanged Code Word is logic 0 0 = The Toggle bit in the previously exchanged Code Word is logic 1
10:0	Message/Unformatte	RO	0x0	Received Code Word Bit 10:0 These bits are encoded as Message Code Field when bit[13] is set to 1, or as Unformatted Code Field when bit[13] is set to 0.
PHY MII 09H: MASTER-SLAVE CONTROL REGISTER 0X09				
Bit	Symbol	Access	Default	Description
15:13	Test mode	RW	0x0	The TX_TCLK signals from the RX_CLK pin is for jitter testing in test modes 2 and 3. When exiting the test mode, hardware reset or software reset through writing register 0x0 bit[15] must be performed to ensure normal operation. 000 = Normal Mode 001 = Test Mode 1 - Transmit Waveform Test 010 = Test Mode 2 - Transmit Jitter Test (MASTER mode) 011 = Test Mode 3 - Transmit Jitter Test (SLAVE mode) 100 = Test Mode 4 - Transmit Distortion Test

				110, 111 = Reserved normal operation.
12	Master/Slave Manual configuration Enable	RW	0x0	<p>This bit is updated immediately after the writing operation; however the configuration does not take effect until any of the following occurs:</p> <ul style="list-style-type: none"> • Software reset is asserted by writing register 0x0 bit[15] • Restart Auto-Negotiation is triggered by writing register 0x0 bit[9] • The port is switched from power down to normal operation by writing register 0x0 bit[11] • Link goes down <p>1 = Manual MASTER/SLAVE configuration 0 = Automatic MASTER/SLAVE configuration.</p>
11	Master/Slave configuration	RW	0x0	<p>This bit is updated immediately after the writing operation; however the configuration does not take effect until any of the following occurs:</p> <ul style="list-style-type: none"> • Software reset is asserted by writing register 0x0 bit[15] • Restart Auto-Negotiation is triggered by writing register 0x0 bit[9] • The port is switched from power

				<p>down to normal operation by writing register 0x0 bit[11]</p> <ul style="list-style-type: none"> • Link goes down <p>This bit is ignored if bit[12] is 0.</p> <p>1 = Manual configuration as MASTER</p> <p>0 = Manual configuration as SLAVE.</p>
10	Port Type	RW	0x0	<p>This bit is updated immediately after the writing operation; however the configuration does not take effect until any of the following occurs:</p> <ul style="list-style-type: none"> • Software reset is asserted by writing register 0x0 bit[15] • Restart Auto-Negotiation is triggered by writing register 0x0 bit[9] • The port is switched from power down to normal operation by writing register 0x0 bit[11] • Link goes down <p>This bit is ignored if bit[12] is 1.</p> <p>1 = Prefer multi-port device (MASTER)</p> <p>0 = Prefer single port device (SLAVE)</p>
9	1000BASE-T Full	RW	0x1	<p>This bit is updated immediately after the writing operation; however the configuration does not take effect until any of the following occurs:</p> <ul style="list-style-type: none"> • Software reset is asserted by writing register 0x0 bit[15] • Restart Auto-Negotiation is triggered by writing register 0x0 bit[9]

				<ul style="list-style-type: none"> The port is switched from power down to normal operation by writing register 0x0 bit[11] Link goes down 1 = Advertise 0 = Not advertised
8	1000BASE-T Half-	RW	0x0	<p>This bit is updated immediately after the writing operation; however the configuration does not take effect until any of the following occurs:</p> <ul style="list-style-type: none"> Software reset is asserted by writing register 0x0 bit[15] Restart Auto-Negotiation is triggered by writing register 0x0 bit[9] The port is switched from power down to normal operation by writing register 0x0 bit[11] Link goes down 1 = Advertise 0 = Not advertised (default)
7:0	Reserved	RW	0x0	Write as 0, ignore on read.
<hr/> PHY MII 0AH: MASTER-SLAVE STATUS REGISTER 0X0A <hr/>				
Bit	Symbol	Access	Default	Description
15	Master/Slave_cfg_error	RO RC SWC LH	0x0	<p>This register bit will clear on read, rising of MII 0.12 and rising of AN complete.</p> <p>1 = Master/Slave configuration fault detected</p> <p>0 = No fault detected</p>
14	Master/Slave Configuration Resolution	RO	0x0	<p>This bit is not valid unless register 0x1 bit5 is 1.</p> <p>1 = Local PHY configuration</p>

				resolved to Master 0 = Local PHY configuration resolved to Slave
13	Local Receiver Status	RO	0x0	1 = Local Receiver OK 0 = Local Receiver not OK
12	Remote Receiver	RO	0x0	1 = Remote Receiver OK 0 = Remote Receiver not OK
11	Link Partner 1000Base-T Full Duplex Capability	RO	0x0	This bit is not valid unless register 0x1 bit5 is 1. 1 = Link Partner supports 1000BASE-T half duplex 0 = Link Partner does not support 1000BASE-T half duplex
10	Link Partner 1000Base-T Half Duplex Capability	RO	0x0	This bit is not valid unless register 0x1 bit5 is 1. 1 = Link Partner supports 1000Base-T full duplex 0 = Link Partner does not support 1000Base-T full duplex
9:8	Reserved	RO	0x0	Reserved
7:0	Idle Error Count	RO RC	0x0	MSB of Idle Error Counter. The register indicates the idle error count since the last read operation performed to this register. The counter pegs at 11111111 and does not roll over.
PHY MII 0DH: MMD ACCESS CONTROL REGISTER 0X0D				
Bit	Symbol	Access	Default	Description
15:14	Function	RW	0x0	00 = Address 01 = Data, no post increment 10 = Data, post increment on reads and writes

				11 = Data, post increment on writes only
13:5	Reserved	RO	0x0	Reserved
4:0	DEVAD	RW	0x0	MMD register device address. 00001 = MMD1 00011 = MMD3 00111 = MMD7
PHY MII 0EH: MMD ACCESS DATA REGISTER 0X0E				
Bit	Symbol	Access	Default	Description
15:0	Address data	RW	0x0	If register 0xD bits [15:14] are 00, this register is used as MMD DEVAD address register. Otherwise, this register is used as MMD DEVAD data register as indicated by its address register.
PHY MII 0FH: EXTENDED STATUS REGISTER 0X0F				
Bit	Symbol	Access	Default	Description
15	1000BASE-X Full Duplex	RO	0x0	1 = PHY supports 1000BASE-X Full Duplex 0 = PHY does not supports 1000BASE-X Full Duplex Always 0.
14	1000BASE-X Half Duplex	RO	0x0	1 = PHY supports 1000BASE-X Half Duplex. 0 = PHY does not support 1000BASE-X Half Duplex. Always 0
13	1000BASE-T Full Duplex	RO	0x1	1 = PHY supports 1000BASE-T Full Duplex 0 = PHY does not supports

				1000BASE-T Full Duplex Always 1
12	1000BASE-T Half Duplex	RO	0x0	1 = PHY supports 1000BASE-T Half Duplex 0 = PHY does not support 1000BASE-T Half Duplex Always 0.
11:0	Reserved	RO	0x0	Reserved
PHY MII 10H: PHY SPECIFIC FUNCTION CONTROL REGISTER				
Bit	Symbol	Access	Default	Description
15:7	Reserved	RO	0x0	Reserved
6:5	Cross_md	RW	0x3	Changes made to these bits disrupt normal operation, thus a software reset is mandatory after the change. And the configuration does not take effect until software reset. 00 = Manual MDI configuration 01 = Manual MDIX configuration 10 = Reserved 11 = Enable automatic crossover for all modes
4	Reserved	RO	0x0	Reserved
3	Crs_on_tx	RW	0x0	This bit is effective in 10BASE-T half-duplex mode and 100BASE-TX mode: 1 = Assert CRS on transmitting or receiving 0 = Never assert CRS on transmitting, only assert it on receiving.
2	En_sqe_test	RW	0x0	1 = SQE test enabled, 0 = SQE test disabled Note: SQE Test is automatically

				disabled in full-duplex mode regardless the setting in this bit.
1	En_pol_inv	RW	0x1	If polarity reversal is disabled, the polarity is forced to be normal in 10BASE-Te. 1 = Polarity Reversal Enabled 0 = Polarity Reversal Disabled
0	Dis_jab	RW	0x0	Jabber takes effect only in 10BASE-Te half-duplex mode. 1 = Disable jabber function 0 = Enable jabber function
PHY MII 11H: PHY SPECIFIC STATUS REGISTER 0X11				
Bit	Symbol	Access	Default	Description
15:14	Speed_mode	RO	0x0	These status bits are valid only when bit11 is 1. Bit11 is set when Auto-Negotiation is completed or Auto-Negotiation is disabled. 11 = Reserved 10 = 1000 Mbps 01 = 100 Mbps 00 = 10 Mbps
13	Duplex	RO	0x0	This status bit is valid only when bit11 is 1. Bit11 is set when Auto-Negotiation is completed or Auto-Negotiation is disabled. 1 = Full-duplex 0 = Half-duplex
12	Page Received real-time	RO	0x0	1 = Page received 0 = Page not received
11	Speed and Duplex Resolved	RO	0x0	When Auto-Negotiation is disabled, this bit is set to 1 for force speed mode.

				1 = Resolved 0 = Not resolved
10	Link status real-time	RO	0x0	1 = Link up 0 = Link down
9:7	Reserved	RO	0x0	Reserved
6	MDI Crossover Status	RO	0x0	This status bit is valid only when bit11 is 1. Bit11 is set when Auto-Negotiation is completed or Auto-Negotiation is disabled. The bit value depends on register 0x10 "PHY specific function control register" bits6~bit5 configurations. Register 0x10 configurations take effect after software reset. 1 = MDIX 0 = MDI
5	Wirespeed downgrade	RO	0x0	1 = Downgrade 0 = No Downgrade
4	Reserved	RO	0x0	Reserved
3	Transmit Pause	RO	0x0	This status bit is valid only when bit11 is 1. Bit11 is set when Auto-Negotiation is completed. This bit indicates MAC pause resolution. This bit is for information purposes only and is not used by the device. When in force mode, this bit is set to be 0. 1 = Transmit pause enabled 0 = Transmit pause disabled
2	Receive Pause	RO	0x0	This status bit is valid only when bit[11] is 1. Bit[11] is set when Auto-Negotiation is completed. This bit indicates MAC pause resolution. This bit is for

				information purposes only and is not used by the device. When in force mode, this bit is set to be 0. 1 = Receive pause enabled 0 = Receive pause disabled
1	Polarity Real Time	RO	0x0	1 = Reverted polarity 0 = Normal polarity
0	Jabber Real Time	RO	0x0	1 = Jabber 0 = No jabber
PHY MII 12H: INTERRUPT MASK REGISTER 0X12				
Bit	Symbol	Access	Default	Description
15	Auto-Negotiation Error INT mask	RW	0x0	1 = Interrupt enable 0 = Interrupt disable
14	Speed Changed INT mask	RW	0x0	same as bit 15
13	Duplex changed INT mask	RW	0x0	same as bit 15
12	Page Received INT mask	RW	0x0	same as bit 15
11	Link Failed INT mask	RW	0x0	same as bit 15
10	Link Succeed INT mask	RW	0x0	same as bit 15
9:7	reserved	RW	0x0	No used.
6	WOL INT mask	RW	0x0	same as bit 15
5	Wirespeed downgraded INT mask	RW	0x0	same as bit 15
4:02	Reserved	RW	0x0	Reserved
1	Polarity changed INT mask	RW	0x0	same as bit 15
0	Jabber Happened INT mask	RW	0x0	same as bit 15

PHY MII 13H: INTERRUPT MASK REGISTER 0X13				
Bit	Symbol	Access	Default	Description
15	Auto-Negotiation Error INT	RW	0x0	Error can take place when any of the following happens: <ul style="list-style-type: none"> • MASTER/SLAVE does not resolve correctly • Parallel detect fault • No common HCD • Link does not come up after negotiation is complete • Selector Field is not equal • flp_receive_idle=true while Autoneg Arbitration FSM is in NEXT PAGE WAIT state 1 = Auto-Negotiation Error takes place 0 = No Auto-Negotiation Error takes place
14	Speed Changed INT	RW	0x0	1 = Speed changed 0 = Speed not changed
13	Duplex changed INT	RW	0x0	1 = duplex changed 0 = duplex not changed
12	Page Received INT	RW	0x0	1 = Page received 0 = Page not received
11	Link Failed INT	RW	0x0	1 = Phy link down takes place 0 = No link down takes place
10	Link Succeed INT	RW	0x0	1 = Phy link up takes place 0 = No link up takes place
9:07	Reserved	RW	0x0	Reserved
6	WOL INT	RW	0x0	1 = PHY received WOL magic frame. 0 = PHY didn't receive WOL magic frame

5	Wirespeed downgraded INT	RW	0x0	1 = speed downgraded. 0 = Speed didn't downgrade.
4:02	Reserved	RW	0x0	Reserved
1	Polarity changed INT	RW	0x0	1 = PHY reversed MDI polarity 0 = PHY didn't revert MDI polarity
0	Jabber Happened INT	RW	0x0	1 = 10BaseT TX jabber happened 0 = 10BaseT TX jabber didn't happen Please refer to mii.1.1 Jabber_Detect.
PHY MII 14H: SPEED AUTO DOWNGRADE CONTROL REGISTER 0X14				
Bit	Symbol	Access	Default	Description
15:12	Reserved	RO	0x0	Reserved
11	En_mdio_latch	RW	0x1	1 = To latch MII/MMD register's read out value during MDIO read 0 = Do not latch MII/MMD register's read out value during MDIO read
10	Start_autoneg	RW	0x0	Set it to cause PHY to restart auto-negotiation.
9	Reverse_autoneg	RW	0x0	1 = reverse the autoneg direction, 10Mb/s has 1st priority, then 100Mb/s and at last 1000Mb/s. 0 = normal autoneg direction
8	Dis_giga	RW	0x0	1 = disable advertise Giga ability in autoneg; 0 = don't disable, so PHY advertises Giga ability based on MII register 0x9.
7:6	Reserved	RO	0x0	Reserved

5	En_speed_downgrade	RW POS	0x1	When this bit is set to 1, the PHY enables smart-speed function. Writing this bit requires a software reset to update. This bit will be set to 1'b0 in UTP_TO_FIBER_FORCE and UTP_TO_FIBER_AUTO mode; else set to 1'b1, only take effect after software reset
4:2	Autoneg retry limit pre-downgrade	RW	0x3	If these bits are set to 3, the PHY attempts five times (set value 3 + additional 2) before downgrading. The number of attempts can be changed by these bits. only take effect after software reset
1	Bp_autospd_timer	RW	0x0	1 = the wirespeed downgrade FSM will bypass the timer used for link stability check; only take effect after software reset 0 = not bypass the timer, then links that established but hold for less than 2.5s would still be taken as failure, autoneg retry counter will increase by 1.
0	Reserved	RO	0x0	Reserved
PHY MII 15H: RX ERROR COUNTER REGISTER 0X15				
Bit	Symbol	Access	Default	Description
15:0	Rx_err_counter	RO	0x0	This counter increase by 1 at the 1st rising of RX_ER when RX_DV is 1. The counter will hold at maximum 16'hFFFF and not roll over.
PHY MII 1EH: DEBUG REGISTER'S ADDRESS OFFSET REGISTER 0X1E				

Bit	Symbol	Access	Default	Description
15:8	Reserved	RO	0x0	Reserved
7:0	Extended Register Address Offset	RW	0x0	It's the address offset of the debug register that will be Write or Read
PHY MII 1FH: DEBUG REGISTER'S DATA REGISTER				
Bit	Symbol	Access	Default	Description
15:0	Extended Register Ddatas	RW	0x0	It's the data to be written to the debug register indicated by the address offset in register 0x1E, or the data read out from that debug register.

PHY EXTENDED REGISTER

PHY EXT 00H: MS CONFIG DEBUG REGISTER 0X00				
Bit	Symbol	Access	Default	Description
7	En_mii_deglitch	RW	0x1	set to 1 to enable rgmii clock deglitch feature
6	uldata_loopback	RW	0x0	when set to 1, upload data to rgmii when remote loopback is set
5	jumbo_enable	RW	0x0	set to 1 to enable jumbo packet transmit and receive
0	MS config for autonege disabled	RW	0x1	Control the master/slave configuration when autonege is disabled and MII register 0x9 Master/Slave Manual configuration Enable is 0.

PHY EXT 04H: MANUAL EEE ABILITY REGISTER 0X04				
Bit	Symbol	Access	Default	Description
15	EEE_nptx_ctrl	RW SWC	0x1	Transmission of EEE nEXT pages control bit.
14	EEE_xnprx_ctrl	RW SWC	0x0	Reception of EEE nEXT pages control bit.
13	EEE_ability_cfg	RW SWC	0x0	1 = for debug, force Local device to enable EEE ability; 0 = the auto-negotiation result decides if Local device enable EEE ability.
12:0	Reserved	RO	0x0	Reserved

PHY EXT 09H: 100BT EXTRA TEST MODE REGISTER 0X09				
Bit	Symbol	Access	Default	Description
12	En_rgmii_crs	RW	0x0	set to 1 to enable rgmii crs pattern
11	En_rgmii_fd_crs	RW	0x0	set to 1 to enable rgmii crs pattern in full duplex mode
10:8	Reserved	RO	0x0	Reserved
7	Jitter_test	RW	0x0	Jitter test enable
6	Over_Shoot_Test	RW	0x0	Overshoot test enable
5	Dcd_test	RW	0x0	Duty cycle distortion test enable
4:3	Pmd_lpbk	RW	0x0	Bit 4: 100BT PMD loopback, loopback TX MLT-3 Encoder output to RX MLT-3 Decoder input; Bit 3: 100BT PMD loopback, loopback TX Scrambler output to RX Descrambler input.
2:1	Pma_lpbk	RW	0x0	Bit 2: 100BT PMA loopback, test Carrier Detect and Link Monitor
0	Pcs_lpbk	RW	0x0	100BT PCS loopback, loopback the serial output of 4B5B encoder on TX side to the serial input of 5B4B decoder on RX side.

PHY EXT 0AH: 10BT DEBUG, LPBKS REGISTER 0X0A				
Bit	Symbol	Access	Default	Description
15:11	Reserved	RO	0x0	Reserved
10	En_10bt_idl	RW	0x0	1 = In 10BT mode , if there's no data or NLP to transmit, shut off DAC; otherwise turn on the DAC; For FPGA due to mdio control, this bit is set to 1'b0 0 = In 10BT, DAC will not be turn off.

9	Bt10_squlch_ctrl	RW	0x1	1 = while receiving pulse_p/n toggle, bt10 carrier sense will be set even though link is no up;
8:5	Reserved	RW	0x0	Reserved
4	Ext_lpbk	RW	0x0	External loopback.
3	Lpbk_ctrl_10bt	RW SWC	0x1	Control the loopback depth in 10BT when MII register 0x0 bit14 loopback is set. 1 = deep Loopback mode 0 = shallow Loopback mode
2:0	Test_mode_10bt	RW SWC	0x0	Test_mode[2:0] is for 10BT test mode select: 3'b001: packet with all ones, 10MHz sine wave, For harmonic test. 3'b010: pseudo random, for TP_IDLE/Jitter/Differential Voltage test. 3'b011: normal link pulse only, 3'b100: 5MHz sin wave. Others: normal mode.

PHY EXT 0CH: PHY CLOCK GATING REGISTER 0X0C

Bit	Symbol	Access	Default	Description
12	En_gate_rx_clk_gmii	RW	0x0	To enable gate phy rx_clk_gmii when phy is link down
11	En_output_clk	RW	0x0	enable debug clock output to rx_clk_rgmii pad
10:08	Clk_out_sel	RW	0x0	select which clock is out to rx_clk_rgmii pad. Clk_out_sel[2]: 1, adc clock is selected; 0, dac clock is selected. Clk_out_sel[1:0]: 2'b00, chn0 is selected; 2'b01, chn1 is selected; 2'b10, chn2 is selected; 2'b11, chn3 is selected
7:04	Tx_clk_delay_sel	RW	0x5	Tx Delay time = 150ps * N – 250ps N is the decimal value of bit[7:4].

				Default value 5 means about 500 ps clock delay compared to txd_rgmii in typical corner..
3	Clk_25m_disable	RW POS	0x0	set to 1 to disable clk 25m pad output
2:01	Clk_25m_sel	RW	0x1	select which clock is output to clk_25m pad 2'b00, 25m from pll; 2'b01, 25m from xtl; 2'b10: 62.5m from pll; 2'b11: 125m from pll
0	Rx_clk_delay_en	RW POS	0x1	set to 1 to enable 1.8ns delay (1000Mbps) 8ns delay (10/100Mbps) on rx_clk_rgmii

PHY EXT 0DH: DELAY AND DRIVER STRENGTH CFG REGISTER 0X0D

Bit	Symbol	Access	Default	Description
15:12	Txc_delay_sel_fe	RW	0xf	selecte tx_clk_rgmii delay in chip which is used to latch txd_rgmii in 100BT/10BTe mode. 150ps step. Default value 15 means about 2ns clock delay compared to txd_rgmii in typical corner.
11:08	Reserved	RW	0xf	Reserved
7:06	Dr_mdio	RW	0x0	driver strength of mdio pad. 2'b11: strongest; 2'b00: weakest
5:04	Dr_rx_rgmii	RW	0x3	driver strength of rx_clk_rgmii ,rx_d and rx_ctl pad. 2'b11: strongest; 2'b00: weakest
3:02	Reserved	RO	0x0	Reserved
1:0	Dr_led	RW	0x0	driver strength of led pad. 2'b11: strongest; 2'b00: weakest

PHY EXT 1EH: RX DELAY CONFIG				
Bit	Symbol	Access	Default	Description
15:10	Reserved	RW	0x0	6b'000000: add 0ps delay 6b'000001: add 200ps delay 6b'000011: add 500ps delay 6b'000111: add 850ps delay 6b'001111, 6b'011111, 6b'111111: no suggested to use
9:0	adc_calib_to	RW	0x300	adc dc calibration timer, 0.5us per step

裕太车通
MotorComm

PHY EXT 27H: SLEEP CONTROL1 0X27				
Bit	Symbol	Access	default	Description
15	En_sleep_sw	RW	0x1	1 = enable sleep mode: PHY will enter sleep mode and close AFE after unplug cable for a timer;
14	Pllon_in_slp	RO	0x0	1 = keep PLL on in sleep mode; 0 = close PLL in sleep mode.
13	Slp_pulse_sw	RW	0x1	when PHY enter sleep, 1 = enable PHY to send out one pulse periodic; 0 = disable PHY to send pulse.
12	En_upd_afe_sbs	RW	0x0	When AFE control is changed, no matter it's triggered by sleep control logic or normal work mode change, 1 = Update AFE step by step; 0 = Update AFE at once.
11:6	Reserved	RO	0x0	Reserved
5	Sleeping	RO	0x0	status register. 1 = PHY is slept; 0 = PHY is waked
4	Reserved	RO	0x0	Reserved
3:0	Slp_state	RO	0x0	FSM state of internal sleep control logic.

PHY EXT 2DH: EEE 1000BT WAKE ERROR TIMER 0X2D				
Bit	Symbol	Access	default	Description
15:0	Eee_wake_time	RW	0x80	lpi_wake_timer in Spec. it's the expected time for the PHY to transition from the LPI mode to normal operation. The condition lpi_wake_timer_done becomes true upon timer expiration. For each transition of

				lpi_wake_timer_done from false to true, the wake error counter MMD 3.22 shall be incremented. This timer shall have a period that does not exceed 16.5 μ s.
PHY EXT 2EH: EEE 100BT WAKE ERROR TIMER 0X2E				
Bit	Symbol	Access	default	Description
15:0	Eee_wake_time_fe	RW	0x370	It's the timer threshold to identify that SNR is OK in 100BT EEE refresh or wake case.

PHY EXT 30H: EEE QUITE TIMER TH 0X30				
Bit	Symbol	Access	default	Description
15:0	quite_timer	RW	0x29f5	Quite timer for 802.3az. Spec is 20~24ms. Real timer = quite_timer * 2048ns. Default is ~22ms.

PHY EXT 34H: EEE CONTROL2 0X34				
Bit	Symbol	Access	default	Description
15	bp_fast_link_down	RW	0x1	1 = bypass fast link down feature

PHY EXT 36H: EEE 100BT CONTROL2 0X36				
Bit	Symbol	Access	default	Description
15:12	Eee_rxidle_t	RW	0x6	lpi_rx_ti_timer in Spec. The minimum duration of received consecutive IDLE symbols before the receiver move to the Idle state. The timer shall have a period between 0.8 μ s and 0.9 μ s.

11:8	Eee_rxquiet_t	RW	0x7	lpi_rx_tq_timer in Spec. 100BT PCS RX counts the maximum duration the PHY stays in the Quiet state before it expects a Refresh signal. If the PHY fails to receive a valid Refresh signal or Wake signal before this timer expires, the receiver shall assume a link failure. The timer shall have a period between 24 ms and 26 ms.
7:0	Eee_rxsleep_t	RW	0x7a	lpi_rx_ts_timer in Spec, 100BT PCS RX counts the maximum duration the PHY is allowed to stay in the Sleep state before assuming a link failure. The timer shall have a period between 240 μ s and 260 μ s
PHY EXT 37H: EEE 100BT CONTROL3 0X37				
Bit	Symbol	Access	default	Description
15:13	fld_timer_sel	RW	0x1	fast link down timer sel. 3'b000=0ms; 3'b001=5ms; 3'b010=10ms; 3'b011=20ms; 3'b100=40ms; 3'b101=80ms; 3'b110=160ms; 3'b111=320ms
12:8	Eee_lnk_fault_t	RW	0x15	lpi_link_fail_timer in Spec. This timer defines the maximum time allowed for the PHY between entry into the Wake state and subsequent entry into the Quiet, Sleep, or Idle states before assuming a link failure. The timer shall have a period between 90 μ s and 110 μ s.
7	Reserved	RW	0x0	Not used.
6	En_eee_rxmode	RW	0x0	To assert RX is active in 100BT EEE or not.

5:0	Eee_rxwake_t	RW	0x14	lpi_rx_tw_timer in Spec. It's the expected duration for the PHY to identify if valid SLEEP symbols for the Refresh state or valid IDLES for the Wake state have been properly received. If none of the SLEEP or IDLE symbols are received when the timer expires, the wake error counter as defined in MMD 3.22 shall be incremented. The timer shall have a period that does not exceed 20.5 μ s.
PHY EXT 38H: PKGEN CFG1 0X38				
Bit	Symbol	Access	default	Description
15:13	Reserved	RO	0x0	Reserved
12	En_pkgen_da_sa	RW	0x0	
11	Pkgen_brdcst	RW	0x0	
10	Pkgchk_txsrc_sel	RW	0x0	
9	Pkgen_en_az	RW	0x0	
8:0	Pkgen_in_az_t	RW	0x1ff	

裕太车通
MotorComm

PHY EXT 80H: VCT_CFG0 0X80				
Bit	Symbol	Access	default	Description
15:13	Small_gap_th	RW	0x4	Small_gap_threshold[9:5].
12:10	Vct_auto_gain_min	RW	0x4	It's the minimal AGC gain that the automatic AGC gain adjustment logic in VCT could reach in VCT test.
9:4	Vct_manu_gain	RW	0x24	The fixed AGC gain used during VCT test. It's valid only when en_vct_manu_gain is 1.
3	En_vct_manu_gain	RW	0x1	To using fixed AGC gain during VCT test.
2	En_gate_vct	RW	0x0	To enable clock gating of VCT module or not when vct_start is not asserted. 1, enable; 0, disable.
1	Vct_tlp_sel	RW	0x1	To send +1 or -1 symbol during VCT test. For FPGA, set it to 1 due to reversed dac polarity
0	En_vct	RW SC	0x0	At the rising edge of this bit, VCT test will start.
PHY EXT 81H: VCT_CFG1 0X81				
Bit	Symbol	Access	default	Description
15	En_chk_fe_found_cnt	RW	0x1	To enable to check the times that far-end echo was found during the VCT test. If the times that far-end echo was found is not bigger than the fe_found_cnt_th, the echo would be taken as invalid.
14:10	Fe_found_cnt_th	RW	0x19	See en_chk_fe_found_cnt.
9:8	Reserved	RW	0x01	Reserved
7:0	Busy_det_th	RW	0x20	The amplitude threshold to judge RX channel is not idle. During VCT RX

				busy detection, if RX signals' amplitude is large than this threshold, RX channel will be treated as busy and VCT test will quit.
<hr/>				
PHY EXT 82H: VCT_CFG2 0X82				
Bit	Symbol	Access	default	Description
15:8	Fecho_amp_th	RW	0x1c	The amplitude threshold to judge far-end echo. During VCT far-end echo detection, the reflections larger than this will be treated as echoes.
7:0	Necho_amp_th	RW	0x32	The amplitude threshold to judge near-end echo. During VCT near-end echo detection, the reflections larger than this will be treated as echoes
<hr/>				
PHY EXT 83H: VCT_CFG3 0X83				
Bit	Symbol	Access	default	Description
15:14	Vct_manu_gain_necho	RW	0x0	
13:8	Num_pulse_intra	RW	0x1e	
7	Tx_sin	RW	0x0	
6	Ignore_ne_found	RW	0x0	
5	Bp_ne_loc	RW	0x0	
4	Vct_fix_echo_dac	RW	0x0	
3:0	Vct_record_cfg	RW	0x0	To control debug register 0x8F~0x92 to record which case's VCT intermediate result. Vct_record_cfg[3:0] = {tx_pair, rx_pair}. For example, 4'b1001 means to record the VCT intermediate status of the case channel 2 transmit and channel 1 receive.

PHY EXT 84H: VCT_MON0 0X84				
Bit	Symbol	Access	default	Description
15	Vct_in_process	RO	0x0	1 = VCT test is still on-going.
14:12	Reserved	RO	0x0	Reserved
11:8	Mdi_busy	RO	0x0	4 channel's MDI is busy or not while doing VCT test.
7:6	Self_st_3	RO	0x0	Intra pair status of channel 3.
5:4	Self_st_2	RO	0x0	Intra pair status of channel 2.
3:2	Self_st_1	RO	0x0	Intra pair status of channel 1.
1:0	Self_st_0	RO	0x0	Intra pair status of channel 0.
PHY EXT 85H: VCT_MON1 0X85				
Bit	Symbol	Access	default	Description
15:12	Inter_st_3	RO	0x0	Inter pair status between channel 3 and other three channels.
11:8	Inter_st_2	RO	0x0	Inter pair status between channel 2 and other three channels.
7:4	Inter_st_1	RO	0x0	Inter pair status between channel 1 and other three channels.
3:0	Inter_st_0	RO	0x0	Inter pair status between channel 0 and other three channels.
PHY EXT 86H: VCT_MON2 0X86				
Bit	Symbol	Access	default	Description
15:12	Inter_err_3	RO	0x0	Error status while doing inter pair test between channel 3 and other three channels.
11:8	Inter_err_2	RO	0x0	Error status while doing inter pair test between channel 2 and other three channels.

7:4	Inter_err_1	RO	0x0	Error status while doing inter pair test between channel 1 and other three channels.
3:0	Inter_err_0	RO	0x0	Error status while doing inter pair test between channel 0 and other three channels.
<hr/>				
PHY EXT 87H: VCT_MON3 0X87				
Bit	Symbol	Access	default	Description
15:0	Self_dmg_loc_0	RO	0x0	The intra pair damage location of channel 0. In unit cm.
<hr/>				
PHY EXT 88H: VCT_MON4 0X88				
Bit	Symbol	Access	default	Description
15:0	Self_dmg_loc_1	RO	0x0	The intra pair damage location of channel 1. In unit cm.
<hr/>				
PHY EXT 89H: VCT_MON5 0X89				
Bit	Symbol	Access	default	Description
15:0	Self_dmg_loc_2	RO	0x0	The intra pair damage location of channel 2. In unit cm.
<hr/>				
PHY EXT 8AH: VCT_MON6 0X8A				
Bit	Symbol	Access	default	Description
15:0	Self_dmg_loc_3	RO	0x0	The intra pair damage location of channel 3. In unit cm.
<hr/>				
PHY EXT 8BH: VCT_MON7 0X8B				
Bit	Symbol	Access	default	Description
15:0	Inter_dmg_loc_0	RO	0x0	The inter pair damage location of channel 0. In unit cm.
<hr/>				
PHY EXT 8CH: VCT_MON8 0X8C				

Bit	Symbol	Access	default	Description
15:0	Inter_dmg_loc_1	RO	0x0	The inter pair damage location of channel 1. In unit cm.
PHY EXT 8DH: VCT_MON9 0X8D				
Bit	Symbol	Access	default	Description
15:0	Inter_dmg_loc_2	RO	0x0	The inter pair damage location of channel 2. In unit cm.
PHY EXT 8EH: VCT_MONA 0X8E				
Bit	Symbol	Access	default	Description
15:0	Inter_dmg_loc_3	RO	0x0	The inter pair damage location of channel 3. In unit cm.
PHY EXT 8FH: VCT_MONB 0X8F				
Bit	Symbol	Access	default	Description
15:10	Ne_loc_phs	RO	0x0	The phase index of the location of the near-end echo.
9:0	Ne_loc_cycle	RO	0x0	The location of the near-end echo, in unit of symbol cycle, which is 8ns.
PHY EXT 90H: VCT_MONC 0X90				
Bit	Symbol	Access	default	Description
15:10	Fe_loc_phs	RO	0x0	The phase index of the location of the Far-end echo..
9:0	Fe_loc_cycle	RO	0x0	The location of the Far-end echo, in unit of symbol cycle, which is 8ns
PHY EXT 91H: VCT_MOND 0X91				
Bit	Symbol	Access	default	Description
15:8	Fe_max_amp	RO	0x0	The far-end echo's amplitude in last intermediate VCT test.

7:0	Ne_max_amp	RO	0x0	The near-end echo's amplitude in last VCT test.
<hr/>				
PHY EXT 92H: VCT_MONE 0X92				
Bit	Symbol	Access	default	Description
15:8	Reserved	RO	0x0	Reserved
7	ne_found	RO	0x0	near end echo is found
6	fe_found	RO	0x0	far end echo is found
5:0	Fe_found_cnt	RO	0x0	The times far-end echo was found in last intermediate VCT test.
<hr/>				
PHY EXT 93H: VCT_MONF 0X93				
Bit	Symbol	Access	default	Description
15:14	Reserved	RO	0x0	Reserved
13:8	Vct_used_agc_3	RO	0x0	The AGC gain used for channel 3 while doing VCT and rx_pair=2'b11.
7:6	Reserved	RO	0x0	Reserved
5:0	Vct_used_agc_2	RO	0x0	The AGC gain used for channel 2 while doing VCT and rx_pair=2'b10.
<hr/>				
PHY EXT 94H: VCT_MONI0 0X94				
Bit	Symbol	Access	default	Description
15:14	Reserved	RO	0x0	Reserved
13:8	Vct_used_agc_1	RO	0x0	The AGC gain used for channel 1 while doing VCT and rx_pair=2'b01.
7:6	Reserved	RO	0x0	Reserved
5:0	Vct_used_agc_0	RO	0x0	The AGC gain used for channel 0 while doing VCT and rx_pair=2'b00.
<hr/>				
PHY EXT 95H: VCT_CFG4 0X95				
Bit	Symbol	Access	default	Description

15:6	Expect_ne_loc	RW	0x1c	
5:0	Num_pulse_inter	RW	0xa	
<hr/>				
PHY EXT 96H: VCT_CFG5 0X96				
Bit	Symbol	Access	default	Description
15	En_inter_small_th	RW	0x1	
14:8	Fecho_amp_th_small	RW	0xf	
7:4	Inter_small_th	RW	0xa	
3:0	Fecho_amp_th_tiny	RW	0xa	
<hr/>				
PHY EXT 97H: VCT_CFG6 0X97				
Bit	Symbol	Access	default	Description
15:8	Fecho_amp_th_huge	RW	0x6e	
7:0	Fecho_amp_th_big	RW	0x50	
<hr/>				
PHY EXT 98H: VCT_CFG7 0X98				
Bit	Symbol	Access	default	Description
15:13	Inter_small_th_small	RW	0x5	
12:8	Inter_small_th_hugh	RW	0x1e	
7:5	Inter_small_th_tiny	RW	0x5	
4:0	Inter_small_th_big	RW	0xa	
<hr/>				
PHY EXT 99H: VCT_CFG8 0X99				
Bit	Symbol	Access	default	Description
15:8	Reserved	RO	0x0	Reserved
7:6	ADC_vref_h_cfg_vct	RW	0x0	
5:4	ADC_vref_l_cfg_vct	RW	0x0	
3:0	VGA_amp_gain_cfg_vct	RW	0xf	

EXT B7H: LED GENERAL CONTROL				
Bit	Symbol	Access	default	Description
15	Col_blk_sel	RW	1'b1	1 = when collision happens, LED blink at Blink Mode2 with higher frequency;
				0 = when collision happens, LED blink at Blink Mode1 with lower frequency;
14	Jabber_led_dis	RW	1'b1	1 = when 10Mb/s Jabber happens, LED will not blink;
				0 = when 10Mb/s Jabber happens, LED will still blink if it's configured to blink on TX.
13	Lpbk_led_dis	RW	1'b1	1 = In internal loopback mode, LED will not blink;
				0 = In internal loopback mode, LED will still blink if it's configured to blink on activity.
12	Dis_led_an_try	RW	1'b0	when auto-negotiation is at LINK_GOOD_CHECK status,
				1 = LED will be on;
				0 = LED will be off.
11:09	Reserved	RO	3'b0	Not used.
8	Led_3_force_en	RW	1'b0	1 = enable LED3 force mode.
7:06	Led_3_force_mode	RW	2'b0	Valid when bit5 is set.
				00 = force LED3 OFF;
				01 = force LED3 ON;
				10 = force LED3 to blink at Blink Mode1;

				11 = force LED3 to blink at Blink Mode2.
5	Led_2_force_en	RW	1'b0	1 = enable LED2 force mode.
4:03	Led_2_force_mode	RW	2'b0	Valid when bit5 is set.
				00 = force LED2 OFF;
				01 = force LED2 ON;
				10 = force LED2 to blink at Blink Mode1;
				11 = force LED2 to blink at Blink Mode2.
2	Led_1_force_en	RW	1'b0	1 = enable LED1 force mode.
1:00	Led_1_force_mode	RW	2'b0	Valid when bit2 is set.
				00 = force LED1 OFF;
				01 = force LED1 ON;
				10 = force LED1 to blink at Blink Mode1;
				11 = force LED1 to blink at Blink Mode2.
EXT B8H: LED1 CONTROL				
Bit	Symbol	Access	default	Description
15:14	Reserved	RO	2'b0	Not used.
13	Led_act_blk_ind_1	RW	1'b0	When traffic is present, make LED1 BLINK no matter the previous LED status is ON or OFF, or make LED1 blink only when the previous LED is ON.
				1 = when bit10 and(or) bit9 are(is) 1 and copper link up and active, make LED1 to blink, no matter bit12~11

				<p>(duplex control) and bit6~4 (speed control) are 1 or 0;</p> <p>0 = when bit10 and(or) bit9 are(is) 1 and copper link up and active, make LED1 to blink only when one (more) of bit12~11 (duplex control) and bit6~4 (speed control) is (are) 1 and related status is (are) matched (ON at certain speed or duplex mode is/are activated);.</p>
12	Led_fdx_on_en_1	RW	1'b0	<p>If BLINK status is not activated, when PHY link up and duplex mode is full duplex,</p> <p>1 = make LED1 ON;</p> <p>0 = don't make LED1 ON;</p>
11	Led_hdx_on_en_1	RW	1'b0	<p>If BLINK status is not activated, when PHY link up and duplex mode is half duplex,</p> <p>1 = make LED1 ON;</p> <p>0 = don't make LED1 ON;</p>
10	Led_txact_blk_en_1	RW	1'b1	<p>If bit13 is 1, or bit13 is 0 and ON at certain speed or duplex more is/are activated, when PHY link up and TX is active,</p> <p>1 = make LED1 BLINK;</p> <p>0 = don't make LED1 BLINK.</p>
9	Led_rxact_blk_en_1	RW	1'b1	<p>If bit13 is 1, or bit13 is 0 and ON at certain speed or duplex more is/are activated, when PHY link up and RX is active,</p> <p>1 = make LED1 BLINK;</p> <p>0 = don't make LED1 BLINK.</p>

8	Led_txact_on_en_1	RW	1'b0	1 = if BLINK status is not activated, when PHY link up and TX is active, make LED1 ON at least 10ms;
7	Led_rxact_on_en_1	RW	1'b0	1 = if BLINK status is not activated, when PHY link up and RX is active, make LED1 ON at least 10ms;
6	Led_gt_on_en_1	RW	1'b1	1 = if BLINK status is not activated, when PHY link up and speed mode is 1000Base-T, make LED1 ON;
5	Led_ht_on_en_1	RW	1'b1	1 = if BLINK status is not activated, when PHY link up and speed mode is 100Base_TX, make LED1 ON;
4	Led_bt_on_en_1	RW	1'b1	1 = if BLINK status is not activated, when PHY link up and speed mode is 10Base-T, make LED1 ON;
3	Led_col_blk_en_1	RW	1'b0	1 = if PHY link up and collision happen, make LED1 BLINK;
2	Led_gt_blk_en_1	RW	1'b0	1 = if PHY link up and speed mode is 1000Base-T, make LED1 BLINK;
1	Led_ht_blk_en_1	RW	1'b0	1 = if PHY link up and speed mode is 100Base-T, make LED1 BLINK;
0	Led_bt_blk_en_1	RW	1'b0	1 = if PHY link up and speed mode is 100Base-T, make LED1 BLINK;

EXT B9H: LED2 CONTROL

Bit	Symbol	Access	default	Description
15:14	Reserved	RO	2'b0	Not used.
13	Led_act_blk_ind_2	RW	1'b0	Same logic as LED1 control.
12	Led_fdx_on_en_2	RW	1'b0	Same logic as LED1 control.
11	Led_hdx_on_en_2	RW	1'b0	Same logic as LED1 control.

10	Led_txact_blk_en_2	RW	1'b0	Same logic as LED1 control.
9	Led_rxact_blk_en_2	RW	1'b0	Same logic as LED1 control.
8	Led_txact_on_en_2	RW	1'b0	Same logic as LED1 control.
7	Led_rxact_on_en_2	RW	1'b0	Same logic as LED1 control.
6	Led_gt_on_en_2	RW	1'b0	Same logic as LED1 control.
5	Led_ht_on_en_2	RW	1'b1	Same logic as LED1 control.
4	Led_bt_on_en_2	RW	1'b0	Same logic as LED1 control.
3	Led_col_blk_en_2	RW	1'b0	Same logic as LED1 control.
2	Led_gt_blk_en_2	RW	1'b0	Same logic as LED1 control.
1	Led_ht_blk_en_2	RW	1'b0	Same logic as LED1 control.
0	Led_bt_blk_en_2	RW	1'b0	Same logic as LED1 control.

EXT BAH: LED BLINK CONTROL

Bit	Symbol	Access	default	Description
15:12	Reserved	RO	4'b0	Not used.
11:09	Duty_sel_2	RW	3'b0	Select duty cycle of Blink Mode2.
				000 = 50% on 50% off;
				001 = 75% on 25% off;
				010 = 25% on 75% off;
				011 = 33% on 67% off;
				100 = 67% on 33% off;
				101 = 17% on 83% off;
				110 = 83% on 17% off;
111 = 8% on 92% off.				
8:06	Freq_sel_2	RW	3'b000	Select frequency of Blink Mode2.
				000 = 2 Hz; 001 = 4Hz;
				010 = 8Hz; 011 = 16Hz;
				100 = 32Hz; 101 = 64Hz;

				110 = 128Hz; 111 = 256Hz.
5:03	Duty_sel_1	RW	3'b000	Select duty cycle of Blink Mode1.
				000 = 50% on 50% off;
				001 = 75% on 25% off;
				010 = 25% on 75% off;
				011 = 33% on 67% off;
				100 = 67% on 33% off;
				101 = 17% on 83% off;
				110 = 83% on 17% off;
				111 = 8% on 92% off.
2:00	Freq_sel_1	RW	3'b110	Select frequency of Blink Mode1.
				000 = 2 Hz; 001 = 4Hz;
				010 = 8Hz; 011 = 16Hz;
				100 = 32Hz; 101 = 64Hz;
				110 = 128Hz; 111 = 256Hz.
EXT BBH: LED3 CONTROL				
Bit	Symbol	Access	default	Description
15:14	Reserved	RO	2'b0	Not used.
13	Led_act_blk_ind_3	RW	1'b0	Same logic as LED1 control.
12	Led_fdx_on_en_3	RW	1'b0	Same logic as LED1 control.
11	Led_hdx_on_en_3	RW	1'b0	Same logic as LED1 control.
10	Led_txact_blk_en_3	RW	1'b0	Same logic as LED1 control.
9	Led_rxact_blk_en_3	RW	1'b0	Same logic as LED1 control.
8	Led_txact_on_en_3	RW	1'b0	Same logic as LED1 control.
7	Led_rxact_on_en_3	RW	1'b0	Same logic as LED1 control.
6	Led_gt_on_en_3	RW	1'b1	Same logic as LED1 control.

5	Led_ht_on_en_3	RW	1'b0	Same logic as LED1 control.
4	Led_bt_on_en_3	RW	1'b0	Same logic as LED1 control.
3	Led_col_blk_en_3	RW	1'b0	Same logic as LED1 control.
2	Led_gt_blk_en_3	RW	1'b0	Same logic as LED1 control.
1	Led_ht_blk_en_3	RW	1'b0	Same logic as LED1 control.
0	Led_bt_blk_en_3	RW	1'b0	Same logic as LED1 control.

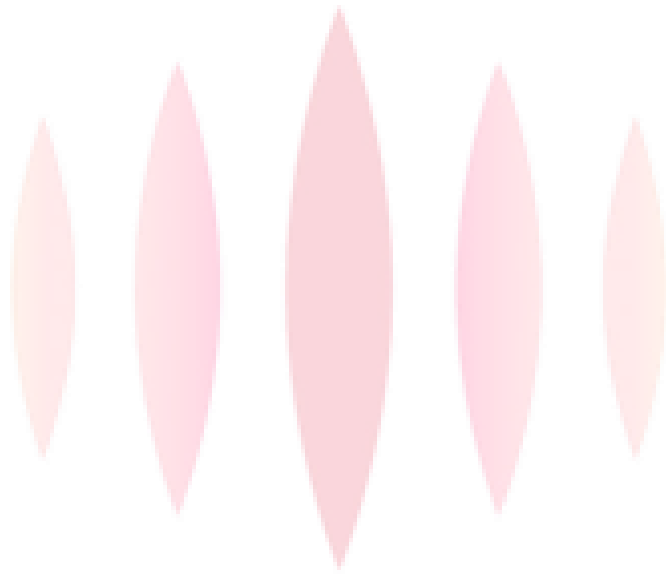

裕太车通
MotorComm

PHY MMD1

PHY MMD1 00H: PMA/PMD CONTROL 1 REGISTER 0X00				
Bit	Symbol	Access	Default	Description
15	Pma_rst	RW SC	0x0	Setting this bit will set all PMA/PMD registers to their default states. This action also initiate a reset in MMD3 and MMD7.
14:0	Reserved	RO	0x0	Reserved
PHY MMD1 05H: PMA/PMD DEVICES IN PACKAGE 0X05				
Bit	Symbol	Access	Default	Description
15:8	Reserved	RO	0x0	Reserved
7	Autoneg_present	RO	0x1	1= Auto-Negotiation present in package; 0= Auto-negotiation not present in package
6:4	Reserved	RO	0x0	Reserved
3	PCS_present	RO	0x1	1= PCS present in package; 0= PCS not present in package.
2	Reserved	RO	0x0	Reserved
1	PMA_present	RO	0x1	1= PMA present in package; 0= PMA not present in package.
0	MII_reg_present	RO	0x1	1= Clause 22 registers present in package; 0= Clause 22 registers not present in package.
PHY MMD1 08H: PMA/PMD STATUS 2 REGISTER 0X08				
Bit	Symbol	Access	Default	Description
15:14	MMD1_present	RO	0x2	Always 2'b10.

13	TX_fault_ability	RO	0x0	PMA/PMD does not have the ability to detect a fault condition on the transmit path.
12	RX_fault_ability	RO	0x0	PMA/PMD does not have the ability to detect a fault condition on the receive path.
11:10	Reserved	RO	0x0	Reserved
9	Extended_ability	RO	0x0	When read as a one, bit 1.8.9 indicates that the PMA/PMD has EXTended abilities listed in register 1.11.
8:0	Extra_abilities	RO	0x0	Reserved

PHY MMD3

Bit	Symbol	Access	Default	Description
PHY MMD3 00H: PCS CONTROL 1 REGISTER 0X00				
15	Pcs_rst	RW SC	0x0	Setting this bit will set all PCS registers to their default states. This action also initiate a reset in MMD1 and MMD7.
14:11	Reserved	RO	0x0	Reserved
10	Clock_stoppable	RW SWC	0x0	Not used.
9:0	Reserved	RO	0x0	Reserved
PHY MMD3 01H: PCS STATUS 1 REGISTER 0X01				
Bit	Symbol	Access	Default	Description
15:12	Reserved	RO	0x0	Reserved
11	Tx_lpi_rxd	RO LH	0x0	When read as 1, it indicates that the transmit PCS has received low power idle signaling one or

				more times since the register was last read. Lach High.
10	Rx_lpi_rxed	RO LH	0x0	When read as 1, it indicates that the receive PCS has received low power idle signaling one or more times since the register was last read. Lach High.
9	Tx_lpi_indic	RO	0x0	When read as 1, it indicates that the transmit PCS is currently receiving low power idle signals.
8	Rx_lpi_indic	RO	0x0	When read as 1, it indicates that the receive PCS is currently receiving low power idle signals.
7:3	Reserved	RO	0x0	Reserved
2	Pcsrx_lnk_status	RO LL	0x0	PCS status, latch low.
1:0	Reserved	RO	0x0	Reserved
PHY MMD3 05H: PCS DEVICES IN PACKAGE REGISTER 0X05				
Bit	Symbol	Access	Default	Description
15:8	Reserved	RO	0x0	Reserved
7	Autoneg_present	RO	0x1	1= Auto-Negotiation present in package; 0= Auto-negotiation not present in package
6:4	Reserved	RO	0x0	Reserved
3	PCS_present	RO	0x1	1= PCS present in package; 0= PCS not present in package.
2	Reserved	RO	0x0	Reserved
1	PMA_present	RO	0x1	1= PMA present in package; 0= PMA not present in package.
0	MII_reg_present	RO	0x1	1= Clause 22 registers present in package;

				0= Clause 22 registers not present in package.
PHY MMD3 08H: PCS DEVICES IN PACKAGE REGISTER 0X08				
Bit	Symbol	Access	Default	Description
15:14	MMD3_present	RO	0x2	Always 2'b10.
13:0	Reserved	RO	0x0	Reserved
PHY MMD3 14H: EEE CONTROL AND CAPABILITY REGISTER 0X14				
Bit	Symbol	Access	Default	Description
15:3	Reserved	RO	0x0	Reserved
2	1000BASE-T EEE	RO	0x1	Always 1. EEE is supported for 1000BASE-T
1	100BASE-TX EEE	RO	0x1	Always 1. EEE is supported for 100BASE-TX
0	Reserved	RO	0x0	Reserved
PHY MMD3 16H: EEE WAKE ERROR COUNTER 0X16				
Bit	Symbol	Access	Default	Description
15:0	Lpi_wake_err_cnt	RO RC SWC	0x0	Count wake time faults where the PHY fails to complete its normal wake sequence within the time required for the specific PHY type.

PHY MMD7

PHY MMD7 00H: AN CONTROL REGISTER 0X00				
Bit	Symbol	Access	Default	Description
15	An_rst	RW SC	0x0	Setting this bit will set all AN registers to their default states. This action also initiate a reset in MMD1 and MMD3.
14	Reserved	RO	0x0	Reserved
13	Xnp_ctrl	RW SWC	0x1	If mii register4 bit12 is set to 0, setting of this bit shall have no effect. 1 = Local device intends to enable the exchange of extended next page; 0 = Local device does not intend to enable the exchange of extended next page;
12:0	Reserved	RO	0x0	Reserved
PHY MMD7 01H: AN STATUS REGISTER 0X01				
Bit	Symbol	Access	Default	Description
15:8	Reserved	RO	0x0	Reserved
7	Xnp_ctrl	RO SWC	0x0	AN result of EXTended nEXT page. 1 = Extended Next Page format is used 0 = Extended Next Page is not allowed
6:0	Reserved	RO	0x0	Reserved
PHY MMD7 05H: AN DEVICES IN PACKAGE REGISTER 0X05				
Bit	Symbol	Access	Default	Description

15:8	Reserved	RO	0x0	Reserved
7	Autoneg_present	RO	0x1	1= Auto-Negotiation present in package; 0= Auto-negotiation not present in package
6:4	Reserved	RO	0x0	s
3	PCS_present	RO	0x1	1= PCS present in package; 0= PCS not present in package.
2	Reserved	RO	0x0	Reserved
1	PMA_present	RO	0x1	1= PMA present in package; 0= PMA not present in package.
0	MII_reg_present	RO	0x1	1= Clause 22 registers present in package; 0= Clause 22 registers not present in package.

 PHY MMD7 3CH: LOCAL DEVICE EEE ABILITY 0X3C

Bit	Symbol	Access	Default	Description
15:3	Reserved	RO	0x0	Reserved
2	EEE_1000BT	RW POS	0x0	PHY's 1000BT EEE ability.
1	EEE_100BT	RW POS	0x0	PHY's 100BT EEE ability.
0	Reserved	RO	0x0	Reserved

 PHY MMD7 3DH: LINK PARTNER EEE ABILITY 0X3D

Bit	Symbol	Access	Default	Description
15:3	Reserved	RO	0x0	Reserved
2	LP_ge_eee_ability	RO	0x0	Link partner's 1000BT EEE ability.
1	LP_ge_eee_ability	RO	0x0	Link partner's 100BT EEE ability.

0	Reserved	RO	0x0	Reserved
---	----------	----	-----	----------

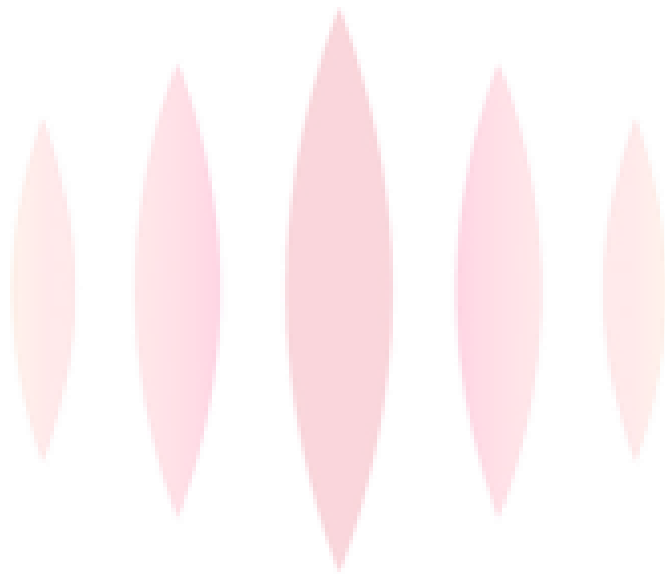

裕太车通
MotorComm

6 TIMING AND AC CHARACTERISTICS

POWER ON SEQUENCE

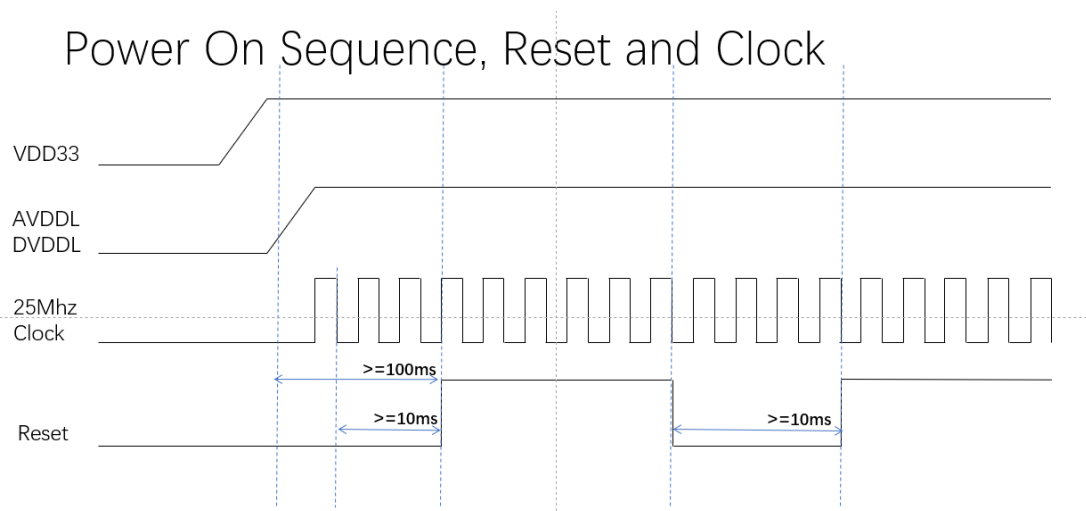

When using crystal, the clock is generated internally after power is stable.

For a reliable power on reset, suggest to keep asserting the reset low long enough (100ms) to ensure the clock is stable and clock-to-reset 10ms requirement is satisfied.

RGMII CHARACTERISTICS

Symbol	Parameter	Conditions	Minimum	Typical	Maximum	Units
VDD33, AVDD33	3.3V Supply Voltage	-	2.97	3.3	3.63	V
1. MDIO, MDC 2. RGMII I/O	2.5V RGMII Supply Voltage	-	2.25	2.5	2.75	V
Voh (3.3V)	Minimum High Level Output Voltage	-	2.4	-	VDD33 + 0.3	V
Voh (2.5V)	Minimum High Level Output Voltage	-	2.0	-	VDD25 + 0.3	V
Vol (3.3V)	Maximum Low Level Output Voltage	-	-0.3	-	0.4	V
Vol (2.5V)	Maximum Low Level Output Voltage	-	-0.3	-	0.4	V
Vih (3.3V)	Minimum High Level Input Voltage	-	2.0	-	-	V
Vil (3.3V)	Maximum Low Level Input Voltage	-	-	-	0.8	V
Vih (2.5V)	Minimum High Level Input Voltage	-	1.7	-	-	V
Vil (2.5V)	Maximum Low Level Input Voltage	-	-	-	0.7	V
Iin	Input Current	Vin=VDD33 or GND	0	-	0.5	μA

RGMII TIMING W/O DELAY

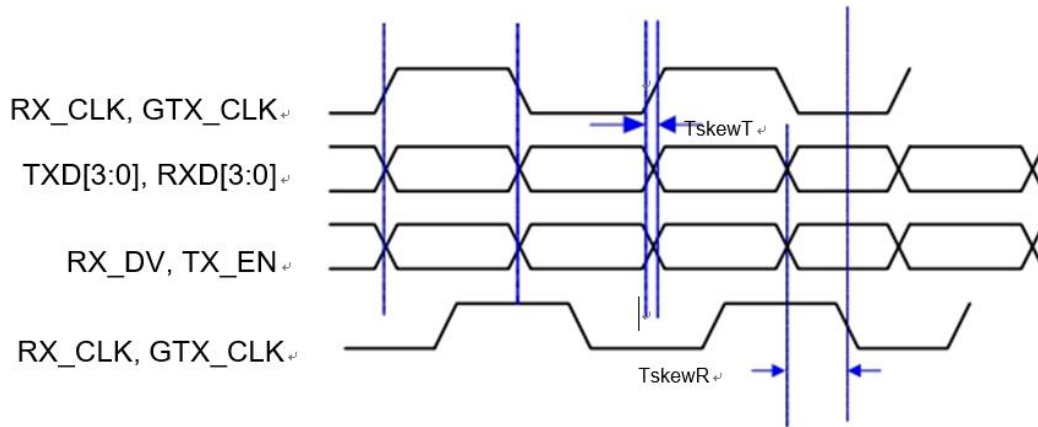

Symbol	Parameter	Min	Typ	Max	Unit
TskewT	Data to clock output skew (at Transmitter)	-500	0	500	ps
TskewR	Data to clock output skew (at Receiver)	1	—	—	ns
T _{yc}	Clock cycle duration	7.2	8.0	8.8	ns
Duty_G	Duty cycle for Gigabit	45	50	55	%
Duty_T	Duty cycle for 10/100T	40	50	60	%
T _r /T _f	Rise/Fall time (20 - 80%)	—	—	0.75	ns

裕太车通
MotorComm

RGMII TIMING WITH INTERNAL DELAY

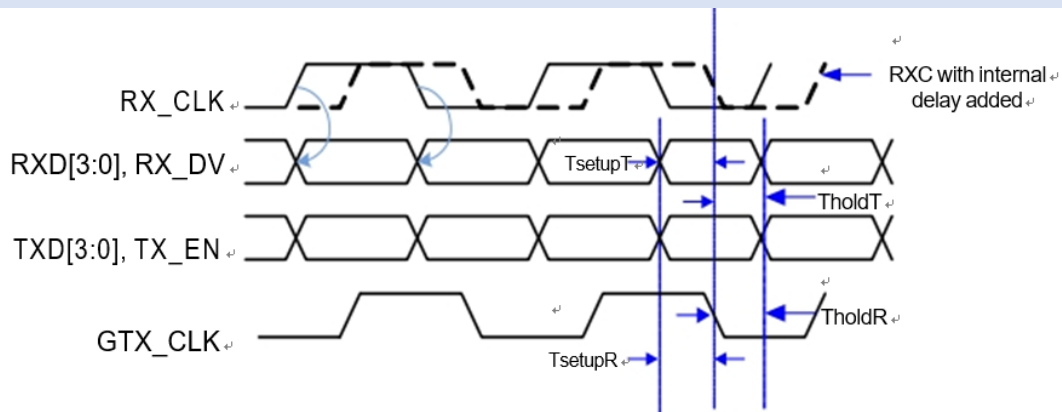

Symbol	Parameter	Min	Typ	Max	Unit
TsetupT	Data to Clock output Setup Time at Transmitter (with delay integrated at transmitter)	1.65	2.0	2.2	ns
TholdT	Clock to Data output Hold Time at Transmitter (with delay integrated at transmitter)	1.65	2.0	2.2	ns
TsetupR	Data to Clock input Setup Time at Receiver (with delay integrated at transmitter)	1.0	2.0		ns
TholdR	Data to Clock output Setup Time at Receiver (with delay integrated at transmitter)	1.0	2.0		ns

MDIO

Symbol	Parameter	Min	Max	Unit
I _{IH}	Input high current	—	0.4	mA
I _{IL}	Input low current	0.4	—	mA
V _{OH}	Output high voltage	2.4	—	V
V _{OL}	Output low voltage	—	0.4	V
V _{IH}	Input high voltage	2.0	—	V
V _{IL}	Input low voltage	—	0.8	V

CRYSTAL REQUIREMENT

Symbol	Description	Min	Typ	Max	Unit
F ref	Crystal Reference Frequency	-	25	-	MHz
F ref Tolerance	Crystal Reference Frequency tolerance	-50	-	50	ppm
Duty Cycle	Reference clock input duty cycle	40	-	60	%
ESR	Equivalent Series Resistance	-		50	ohm
DL	Drive Level	-	-	0.5	mW

OSCILLATOR/EXTERNAL CLOCK REQUIREMENT

Parameter	Condition	Min	Typ	Max	Unit
Frequency			25		MHz
Frequency tolerance	Ta= -40~85 C	-50		50	PPM
Duty Cycle		40	-	60	%
Peak to Peak Jitter				200	ps
Vih		AVDDL-0.2		AVDDL+0.2	V
Vil				0.4	V
Rise Time	10%~90%			10	ns
Fall Time	10%~90%			10	ns
Temperature Range	YT8512H	-40		85	°C
Temperature Range	YT8512C	0		70	°C

MotorComm

7 POWER REQUIREMENTS

POWER REQUIREMENT

Symbol	Parameter	Conditions	Minimum	Typical	Maximum	Units
VDD33, AVDD33	3.3V Supply Voltage	-	2.97	3.3	3.63	V
1. MDIO, MDC 2. RGMII I/O	2.5V RGMII Supply Voltage	-	2.25	2.5	2.75	V
Voh (3.3V)	Minimum High Level Output Voltage	-	2.4	-	VDD33 + 0.3	V
Voh (2.5V)	Minimum High Level Output Voltage	-	2.0	-	VDD25 + 0.3	V
Vol (3.3V)	Maximum Low Level Output Voltage	-	-0.3	-	0.4	V
Vol (2.5V)	Maximum Low Level Output Voltage	-	-0.3	-	0.4	V
Vih (3.3V)	Minimum High Level Input Voltage	-	2.0	-	-	V
Vil (3.3V)	Maximum Low Level Input Voltage	-	-	-	0.8	V
Vih (2.5V)	Minimum High Level Input Voltage	-	1.7	-	-	V
Vil (2.5V)	Maximum Low Level Input Voltage	-	-	-	0.7	V
Iin	Input Current	Vin=VDD33 or GND	0	-	0.5	μA

裕太车通
MotorComm

POWER CONSUMPTION (TYPICAL)

MODE		3.3V Domain		Power (mW)
		VDD33(Pin3)	AVDD33(Pin14)	
Reset		3	12	47.2
Sleep		2	6	24.1
power down		3	12	48.8
Active	normal unplug	14	25	129.4
	link 10M	6	24	100.7
	link 100M	19	27	153.5
	link 1000M	118	75	633.6
Traffic	link 10M	7	31	125.7
	link 100M	19	29	158.4
	link 1000M	131	81	699.6

Using internal switching regulator, Inductor P/N:SLW3012S4R7MST DCR=0.12ohm

裕太车通
MotorComm

8 MECHANICAL AND THERMAL

ROHS-COMPLIANT PACKAGING

Motor-comm offers an RoHS package that is compliant with RoHS

Part Number	Status	Package Qty	Op temp (°C)	Note
YT8511C	Active	3000; tape and reel	0 to 70	
YT8511H	Active	3000; tape and reel	-40 to 85	

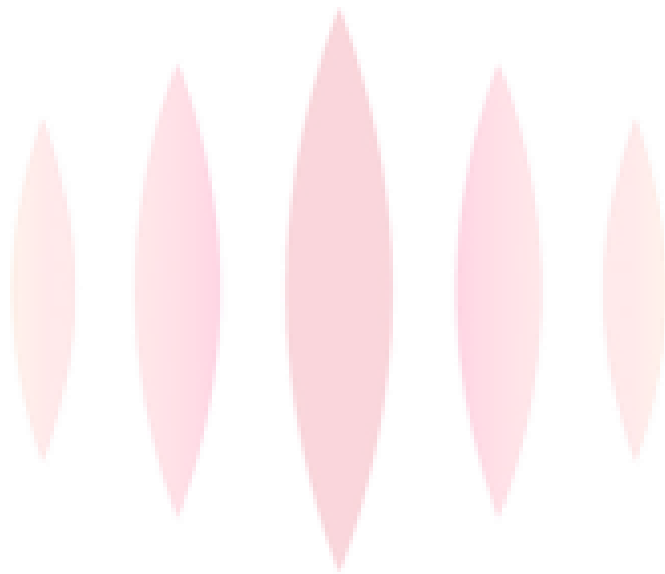

裕太车通
MotorComm

9 MECHANICAL INFORMATION

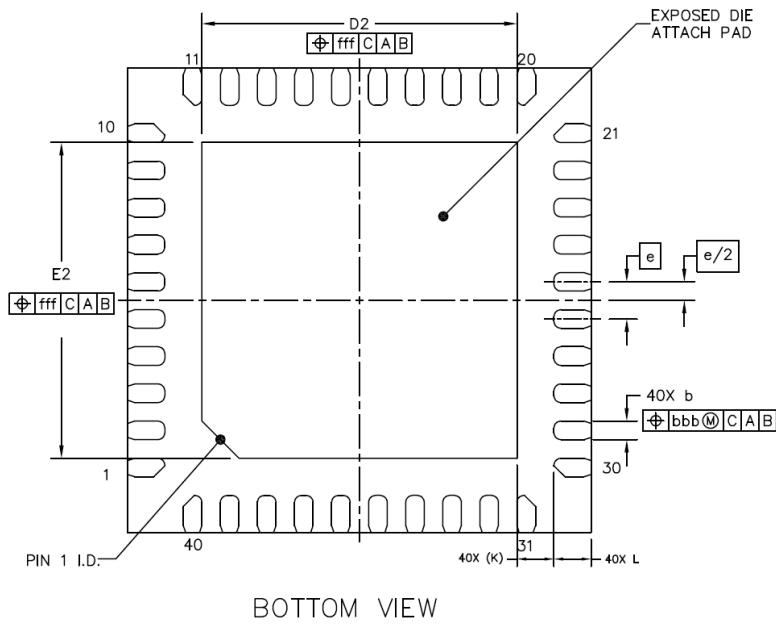
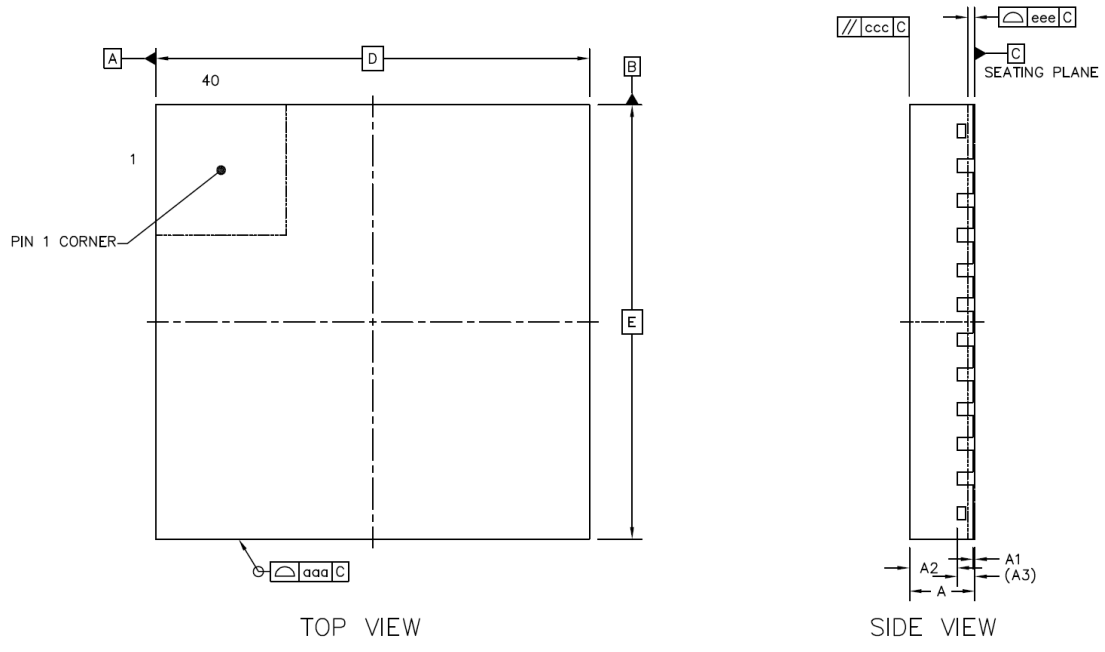

		SYMBOL	MIN	NOM	MAX
TOTAL THICKNESS		A	0.7	0.75	0.8
STAND OFF		A1	0	0.02	0.05
MOLD THICKNESS		A2	---	0.55	---
L/F THICKNESS		A3	0.203 REF		
LEAD WIDTH		b	0.15	0.2	0.25
BODY SIZE	X	D	5 BSC		
	Y	E	5 BSC		
LEAD PITCH		e	0.4 BSC		
EP SIZE	X	D2	3.3	3.4	3.5
	Y	E2	3.3	3.4	3.5
LEAD LENGTH		L	0.3	0.4	0.5
LEAD TIP TO EXPOSED PAD EDGE		K	0.4 REF		
PACKAGE EDGE TOLERANCE		aaa	0.1		
MOLD FLATNESS		ccc	0.1		
COPLANARITY		eee	0.08		
LEAD OFFSET		bbb	0.07		
EXPOSED PAD OFFSET		fff	0.1		

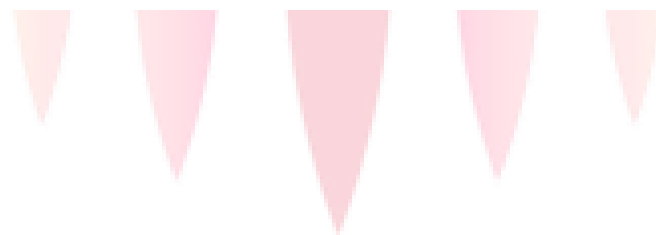

裕太车通
MotorComm

10 ORDERING INFORMATION

Part Number	Grade	Package	Packaging	Status	Operation Temp
YT8511C	Consumer	QFN 40 5x5 mm	Tape & Reel Qty: 3000	Mass Production	0 ~70 °C
YT8511H	Industrial	QFN 40 5x5 mm	Tape & Reel Qty: 3000	Mass Production	-40 ~ 85 °C

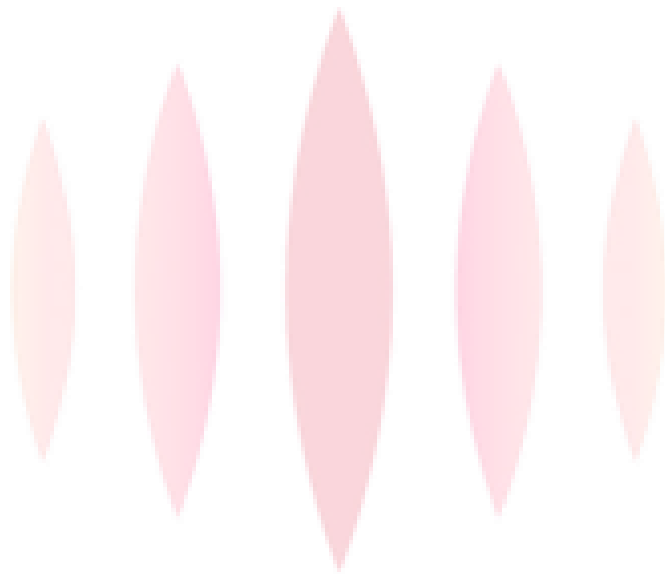

裕太车通
MotorComm