

EVB Schematics For RK3568

RK_EVB1_RK3568_DDR4P216SD6_V1.0

Main Functions Introduction

- 1) PMIC: RK809-5+DiscretePower
- 2) RAM: DDR4 2x16Bit
- 3) ROM: eMMC5.1+SPI Falsh,Option Nand Flash
- 4) Support: Micro SD Card3.0
- 5) Support: 1 x USB3.0 OTG + 1 x USB3.0 HOST + 2 x USB2.0 HOST
- 6) Support: 1 x SATA3.0 Connector (7pin) + 4 pin Power Connector
- 7) Support: 1 x 2Lanes PCIe3.0 Connector (RC Mode)
- 8) Support: 1 x 4Lanes MIPI CSI Camera or 2 x 2Lanes MIPI CSI Camera
- 9) Support: Parallel CIF Connector(Option-Ext Board)
- 10) Support: 1 x HDMI2.0 TX
- 11) Support: eDP to VGA TX or 1 x 4Lanes eDP with Touch Connector(Option)
- 12) Support: 2 x 4Lanes MIPI DSI or 1 x 4Lanes MIPI DSI + 1 x LVDS with Touch Connector
- 13) Support: a/b/g/n/ac 2X2 WIFI,BT5.0
- 14) Support: 2 x 10/100/1000 Ethernet(RGMII)
- 15) Support: IR Receiver
- 16) Support: Optical S/PDIF TX
- 17) Support: Headphone output,1 x ECM MIC and Speaker out(1.3W@8ohm)
- 18) Support: Array MIC Connector(Ext Board PDM)
- 19) Support: Gyroscope+G-sensor
- 20) Support: Array Key(MENU,VOL+,VOL-,ESC),Reset,Power on/off Key
- 21) Support: 3 x UART + 2 x UART(Option)
- 22) Support: 1 x CAN FD
- 23) Support: 5 x SARADC
- 24) Support: Debug UART to USB connector and JTAG Connector



www.t-firefly.com

Title: Cover Page

File: ROC-3568-PC

REV: 00

Create Date: Monday, March 30, 2020

Page Num: 1

Modify Date: Wednesday, May 19, 2021

Page Total: 45

Table of Content

Page 1	00.Cover Page
Page 2	01.Index and Notes
Page 3	02.Revision History
Page 4	03.Block Diagram
Page 5	04.Power Diagram
Page 6	05.Power Sequence/IO Domain Map
Page 7	06.UART Map
Page 8	07.I2C Bus Map
Page 9	08.USB3/PCIE30 Fun Map
Page 10	10.RK3568 Power/GND
Page 11	11.RK3568_DDR PHY
Page 12	12.RK3568_OSC/PLL/PMUIO
Page 13	13.RK3568_Flash/SD Controller
Page 14	14.RK3568_USB/PCIE/SATA PHY
Page 15	15.RK3568_SARADC/GPIO
Page 16	16.RK3568_VI Interface
Page 17	17.RK3568_VO Interface_1
Page 18	18.RK3568_VO Interface_2
Page 19	19.RK3568_Audio Interface
Page 20	20.Power_DC IN
Page 21	21.Power_PMIC
Page 22	22.Power_other
Page 23	23.Power_Flash Power Manage
Page 24	25.USB2/USB3 Port
Page 25	33.DRAM-DDR4_2x16bit_96P
Page 26	40.Flash-eMMC Flash
Page 27	41.Flash-Nand Flash(Optional)
Page 28	42.Flash-MicroSD Card
Page 29	43.Flash-SPI FLASH
Page 30	47.VI-Camera_MIPI-CSI
Page 31	50.VO-HDMI2.0 TX
Page 32	52.VO-LCM_MIPI-DSI_TX0/LVDS_TX0
Page 33	54.VO-LCM_MIPI-DSI_TX1
Page 34	56.VO-LCM_eDP(Optional)
Page 35	59.VO-VGA Output(RTD2166)
Page 36	62.WIFI/BT-SDIO_2T2R + UART
Page 37	67.Ethernet-GEPHY_RGMII0
Page 38	68.Ethernet-GEPHY_RGMII1
Page 39	70.Audio Port
Page 40	76.Audio-S/PDIF TX Port
Page 41	77.Audio-MIC Array Interface
Page 42	82.PCIE-PCIE3.0 Slot
Page 43	83.SATA-SATA3.0 Slot_7P
Page 44	90.Sensor/IR Receiver
Page 45	91.Debug UART/JTAG Port
Page 46	92.KEY Array
Page 47	95.UART/CAN Port
Page 48	97.Power Test-Current Det MCU
Page 49	98.Power Test-ADC
Page 50	99.Mark/Hole/Heatsink
Page 51	
Page 52	
Page 53	

Generate Bill of Materials

Header:

Item\Part\Description\PCB Footprint\Reference\Quantity\Option

Combined property string:

{Item}\{Value}\{Description}\{PCB Footprint}\{Reference}\{Quantity}\{Option}

Description

Note

Option

Notes

NOTE 1:

Component parameter description

1. DNP stands for component not mounted temporarily
2. If Value or option is DNP, which means the area is reserved without being mounted

NOTE 2:

Please use our recommended components to avoid too many changes.
For more informations about the second source,please refer to our AVL.

		www.t-firefly.com	
Title: Index and Notes			
File: ROC-3568-PC		REV: V0.1	
Create Date: Monday, March 30, 2020	Page Num: 2		
Modify Date: Wednesday, May 19, 2021	Page Total: 45		

RK3568 Ref Block Diagram

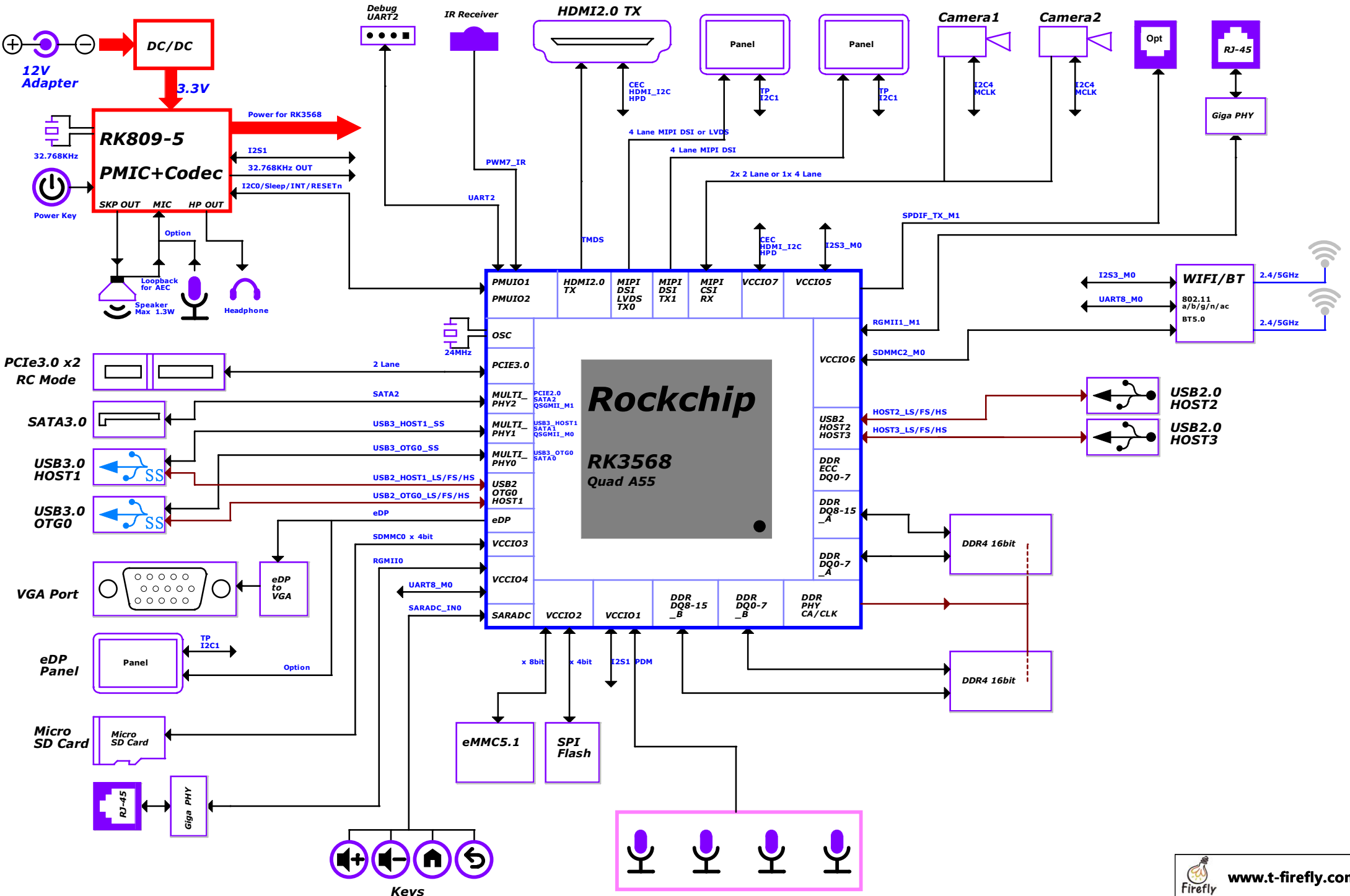

Rockchip Confidential

Power Diagram

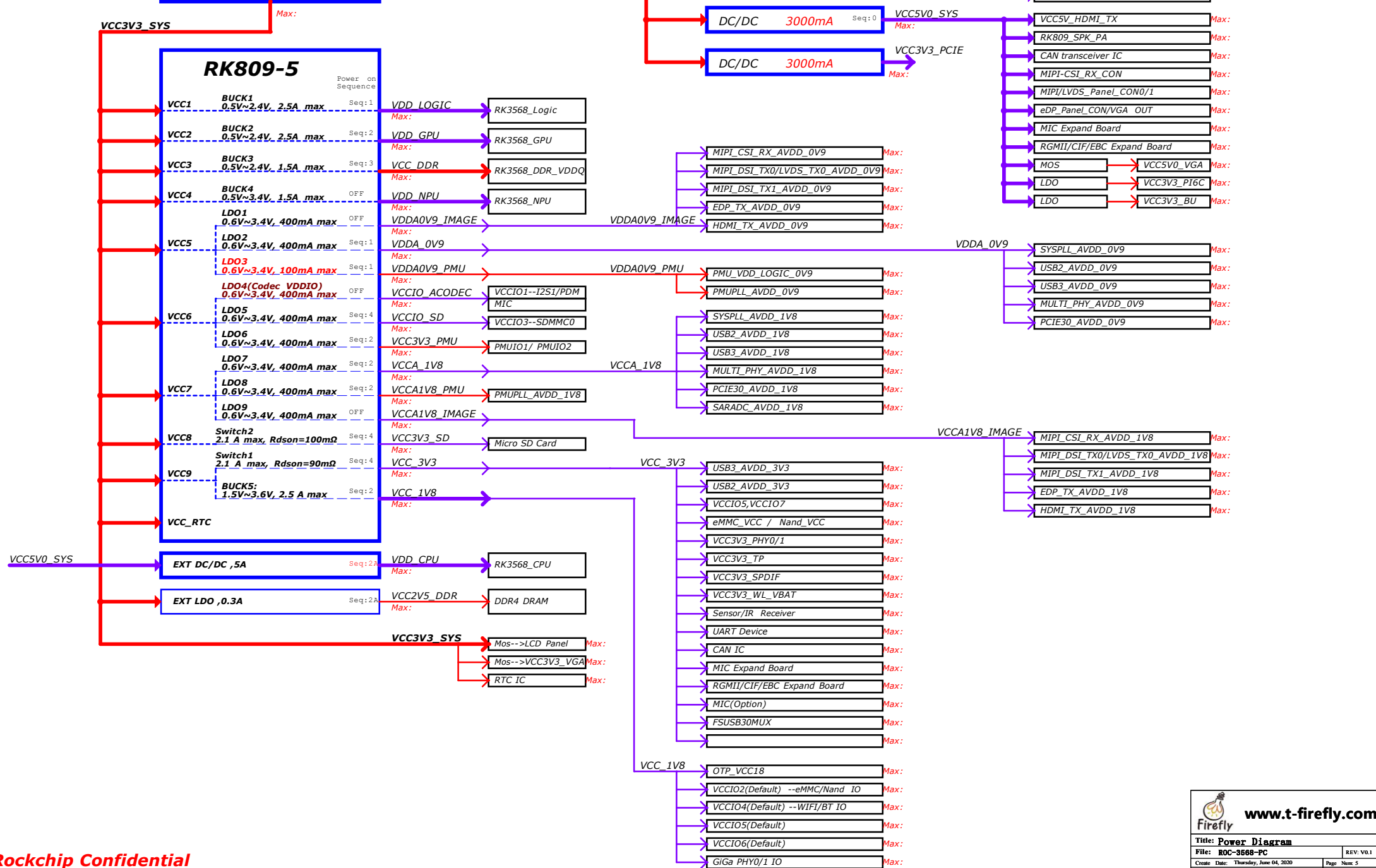
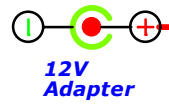

Power Sequence

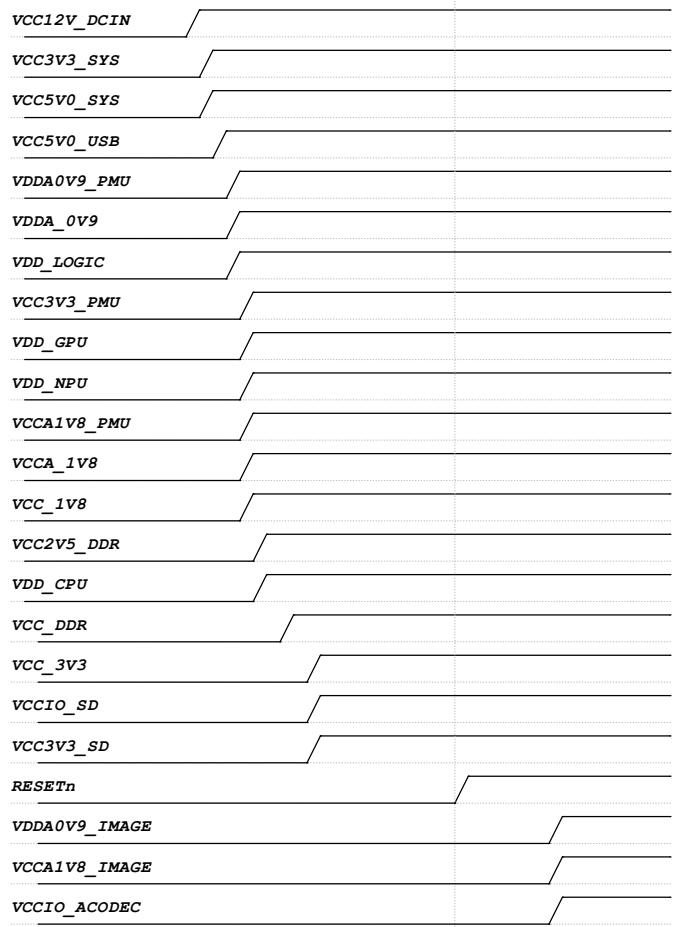

Power Supply	PMIC Channel	Supply Limit	Power Name	Time Slot	Default Voltage	Default ON/OFF	Sleep ON/OFF	Peak Current	Sleep Current
VCC3V3_SYS	RK809_BUCK1	2.5A	VDD_LOGIC	Slot:1	0.9V	ON	OFF	TBD	TBD
VCC3V3_SYS	RK809_BUCK2	2.5A	VDD_GPU	Slot:2	0.9V	ON	OFF	TBD	TBD
VCC3V3_SYS	RK809_BUCK3	1.5A	VCC_DDR	Slot:3	ADJ FB=0.8V	ON	ON	TBD	TBD
VCC3V3_SYS	RK809_BUCK4	1.5A	VDD_NPU	N/A	0.9V	OFF	OFF	TBD	TBD
VCC3V3_SYS	RK809_LDO1	0.4A	VDDA0V9_IMAGE	N/A	0.9V	OFF	OFF	TBD	TBD
	RK809_LDO2	0.4A	VDDA_0V9	Slot:1	0.9V	ON	OFF	TBD	TBD
	RK809_LDO3	0.1A	VDDA0V9_PMU	Slot:1	0.9V	ON	ON	TBD	TBD
VCC3V3_SYS	RK809_LDO4	0.4A	VCCIO_ACODEC	N/A	3.3V	OFF	OFF	TBD	TBD
	RK809_LDO5	0.4A	VCCIO_SD	Slot:4	3.3V	ON	OFF	TBD	TBD
	RK809_LDO6	0.4A	VCC3V3_PMU	Slot:2	3.3V	ON	ON	TBD	TBD
VCC3V3_SYS	RK809_LDO7	0.4A	VCCA_1V8	Slot:2	1.8V	ON	OFF	TBD	TBD
	RK809_LDO8	0.4A	VCCA1V8_PMU	Slot:2	1.8V	ON	ON	TBD	TBD
VCC3V3_SYS	RK809_LDO9	0.4A	VCCA1V8_IMAGE	N/A	1.8V	OFF	OFF	TBD	TBD
	RK809_SW2 100mohm	2.1A	VCC3V3_SD	Slot:4	3.3V	ON	OFF	TBD	TBD
VCC3V3_SYS	RK809_SW1 90mohm	2.1A	VCC_3V3	Slot:4	3.3V	ON	OFF	TBD	TBD
	RK809_BUCK5	2.5A	VCC_1V8	Slot:2	1.8V	ON	OFF	TBD	TBD
	RK809_RESETh			Slot:4+5					
VCC12V_DCIN	EXT BUCK	3.0A	VCC3V3_SYS	Slot:0	3.3V	ON	ON	TBD	TBD
VCC12V_DCIN	EXT BUCK	3.0A	VCC5V0_SYS	Slot:0	5.0V	ON	OFF	TBD	TBD
VCC5V0_SYS	EXT BUCK	6.0A	VDD_CPU	Slot:2A	1.025V	ON	OFF	TBD	TBD
VCC3V3_SYS	EXT LDO	0.3A	VCC2V5_DDR	Slot:2A	2.5V	ON	ON	TBD	TBD

IO Power Domain Map

Updates must be Revision accordingly!

IO Domain	Pin Num	Support IO Voltage		Actual assigned IO Domain Voltage			Notes
		3.3V	1.8V	Supply Power Net Name	Power Source	Voltage	
PMUIO1	Pin Y20	✓	✗	VCC3V3_PMU	VCC3V3_PMU	3.3V	
PMUIO2	Pin W19	✓	✓	VCC3V3_PMU	VCC3V3_PMU	3.3V	
VCCIO1	Pin H17	✓	✓	VCCIO_ACODEC	VCCIO_ACODEC	3.3V	
VCCIO2	Pin H18	✓	✓	VCCIO_FLASH	VCC_1V8	1.8V	PIN "FLASH_VOL_SEL" must be logic High if VCCIO_FLASH=3.3V, FLASH_VOL_SEL must be logic low
VCCIO3	Pin L22	✓	✓	VCCIO_SD	VCCIO_SD	3.3V	
VCCIO4	Pin J21	✓	✓	VCCIO4	VCC_1V8	1.8V	
VCCIO5	Pin V10 Pin V11	✓	✓	VCCIO5	VCC_3V3	3.3V	
VCCIO6	Pin R9 Pin U9	✓	✓	VCCIO6	VCC_1V8	1.8V	
VCCIO7	Pin V12	✓	✓	VCCIO7	VCC_3V3	3.3V	



www.t-firefly.com

Title: Power Sequence/IO Domain Map
 File: ROC-3568-PC
 Create Date: Monday, March 30, 2020
 Modify Date: Wednesday, May 19, 2021
 Page Num: 6
 Page Total: 45

UART MAP

RK3568

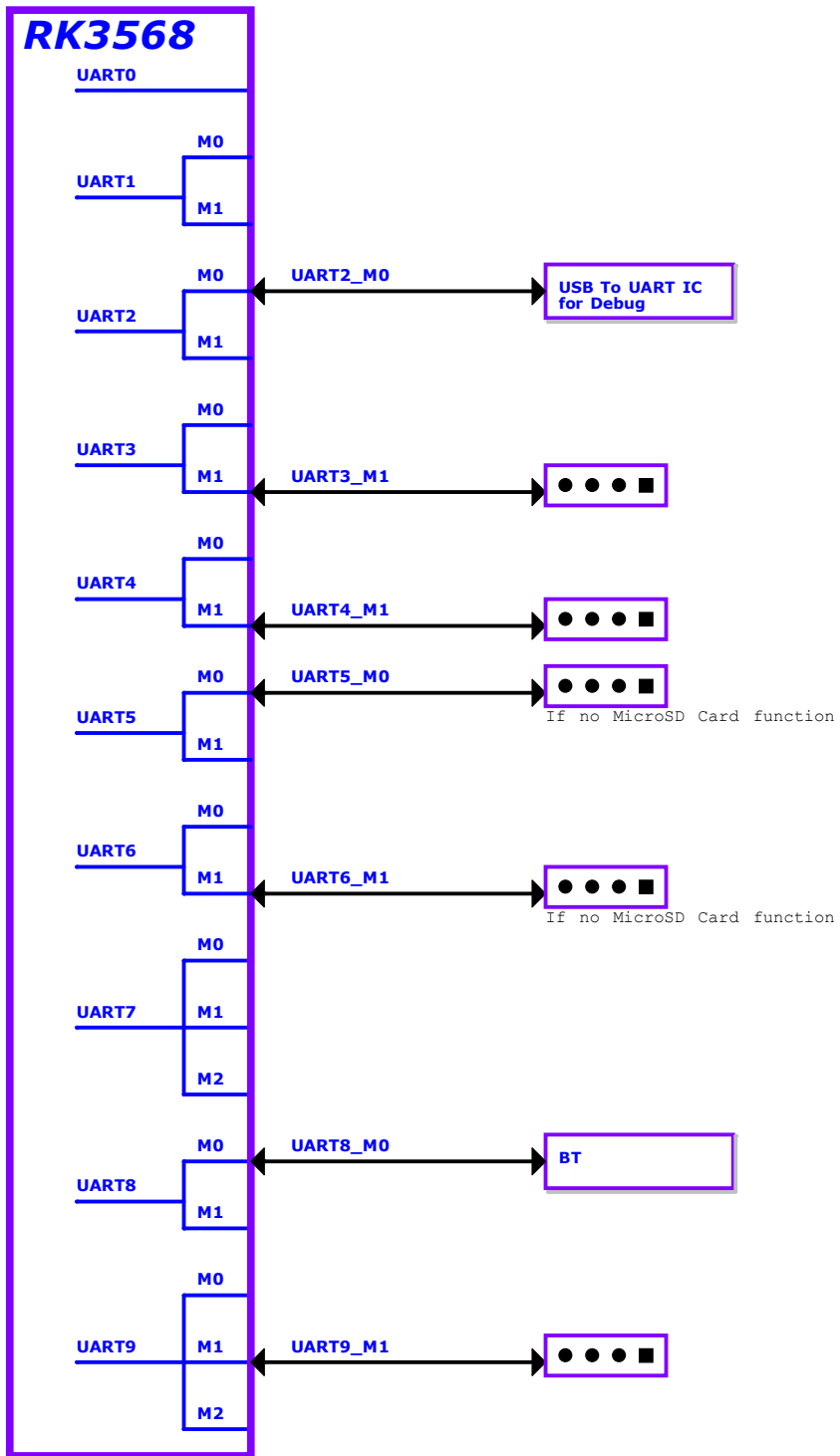

I2C MAP

RK3568

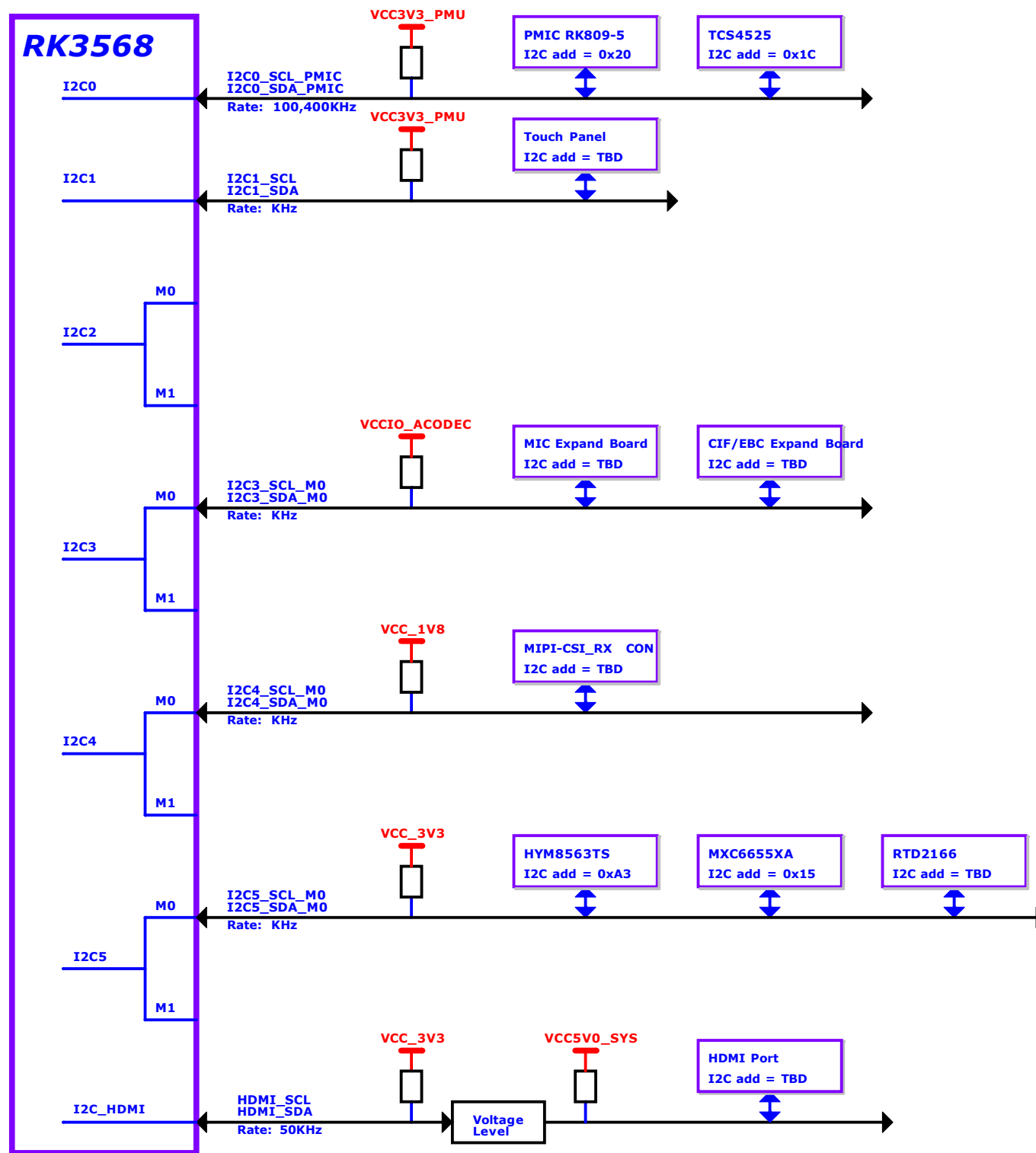

USB3.0 OTG0

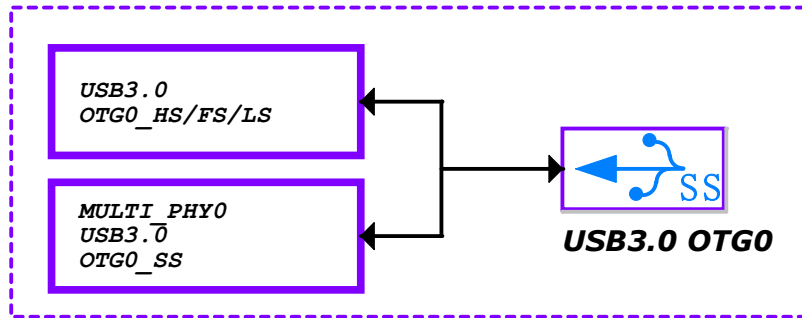

USB3.0 HOST1

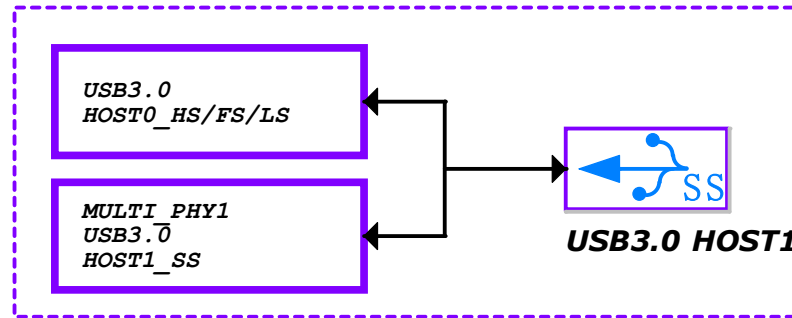

PCIe3.0 PHY

Option1	PCIe3.0 x2Lane	PCIe30_REFCLK (RC/EP:input)	PCIe30_TX0 PCIe30_RX0 PCIe30_TX1 PCIe30_RX1	PCIe30X2_CLKREQn PCIe30X2_WAKEn PCIe30X2_PERSTn PCIe30X2_BUTTONRSTn	RC or EP
Option2	PCIe3.0 x1Lane + PCIe3.0 x1Lane	PCIe30_REFCLK (RC:input)	PCIe30_TX0 PCIe30_RX0	PCIe30X2_CLKREQn PCIe30X2_WAKEn PCIe30X2_PERSTn PCIe30X2_BUTTONRSTn	Only RC
			PCIe30_TX1 PCIe30_RX1	PCIe30X1_CLKREQn PCIe30X1_WAKEn PCIe30X1_PERSTn PCIe30X1_BUTTONRSTn	Only RC

PCIe3.0 REFCLK

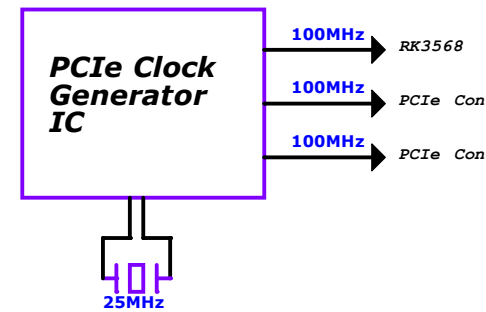

PCIe2.0 PHY

MULTI_PHY2	PCIe2.0 x1Lane	PCIe20_REFCLK (RC:output)	PCIe20_TX PCIe20_RX	PCIe20_CLKREQn PCIe20_WAKEn PCIe20_PERSTn PCIe20_BUTTONRSTn	Only RC
-------------------	-----------------------	---------------------------	------------------------	--	----------------

PCIe2.0 REFCLK

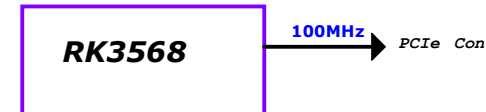

RK3568_ABCDE (Power&Gnd)

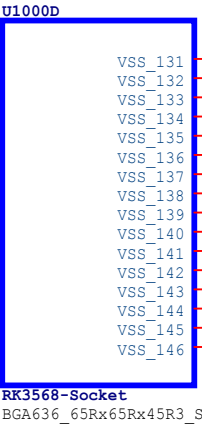
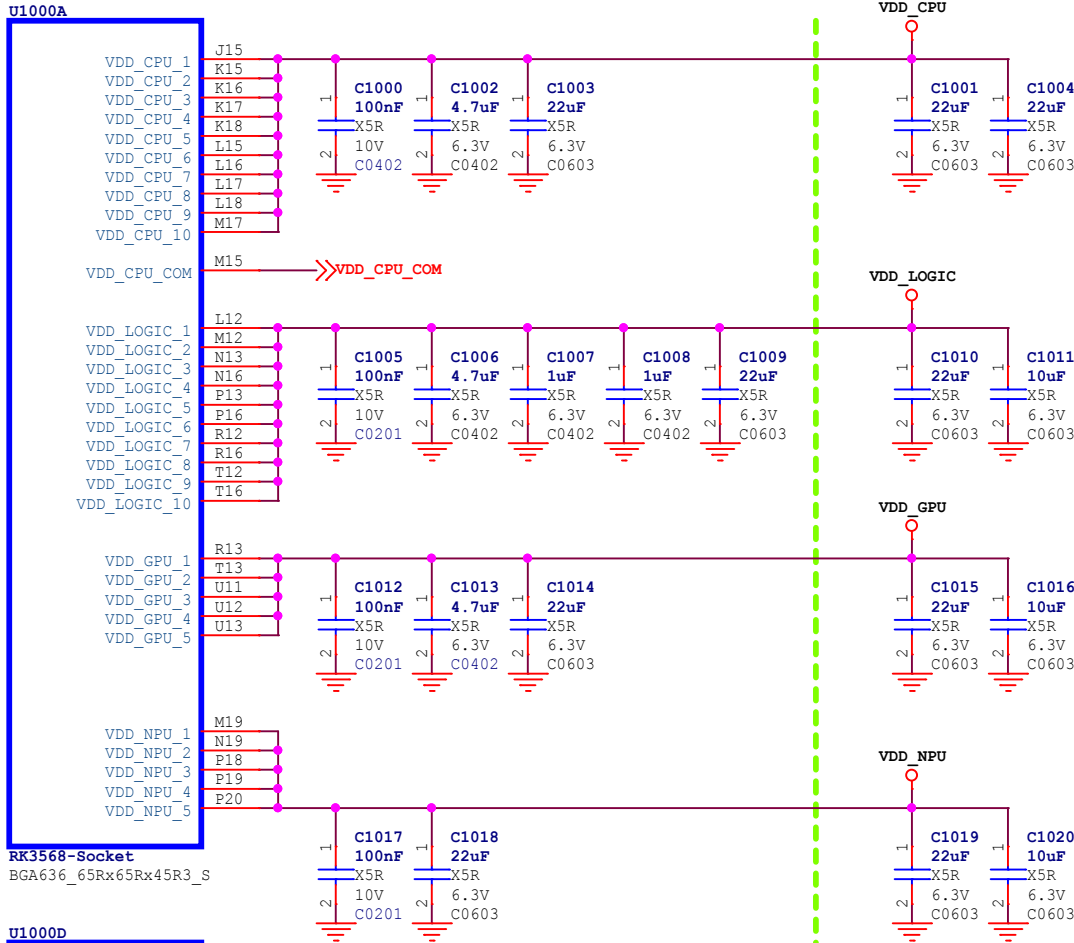

Caps should be placed under the U1000 package

Caps should be placed close to the U1000 package

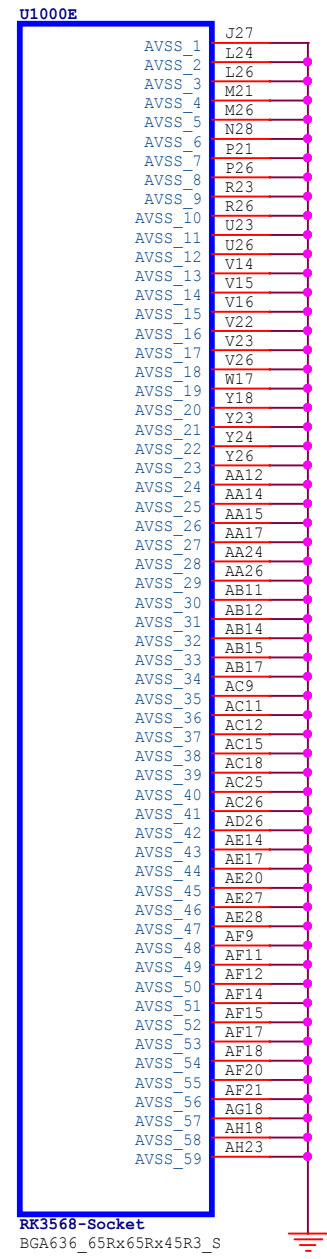
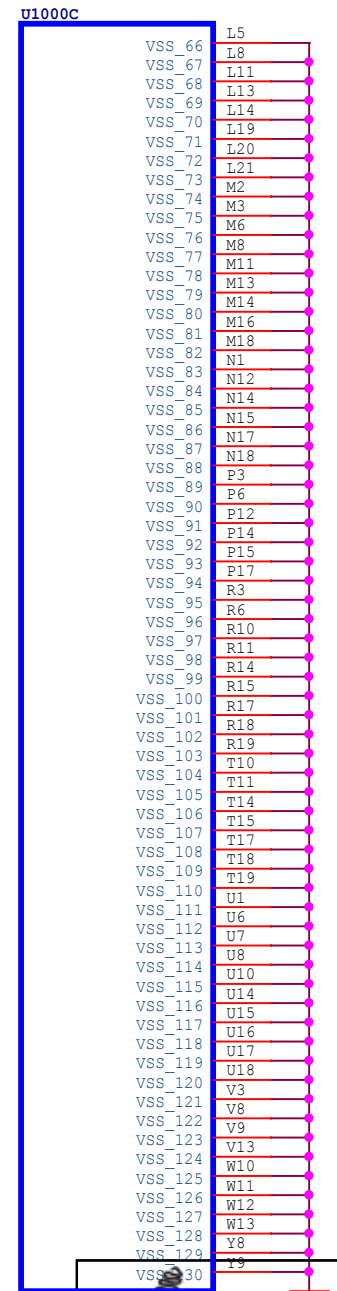
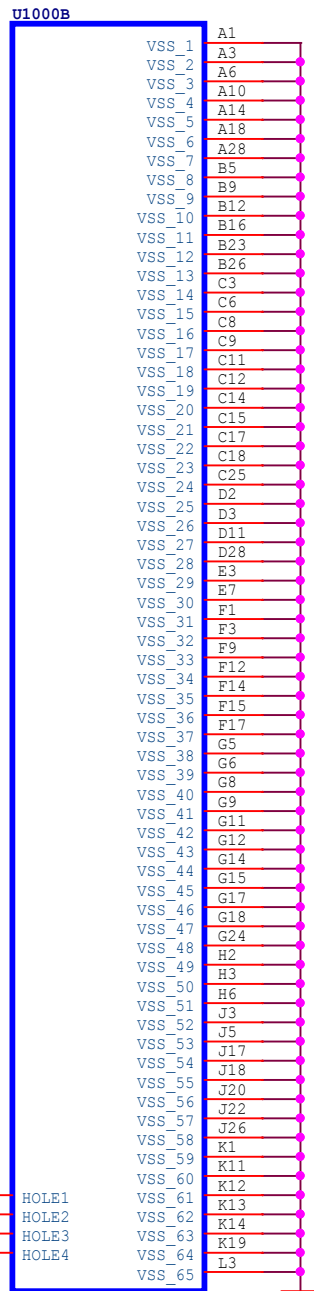
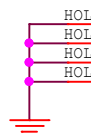

Title: RK3568 Power/GND		
File: ROC-3568-PC	REV: V0.1	
Create Date: Monday, March 30, 2020	Page Num: 10	
Modify Date: Wednesday, May 19, 2021	Page Total: 45	

RK3568_F (DDR PHY)

U1000F

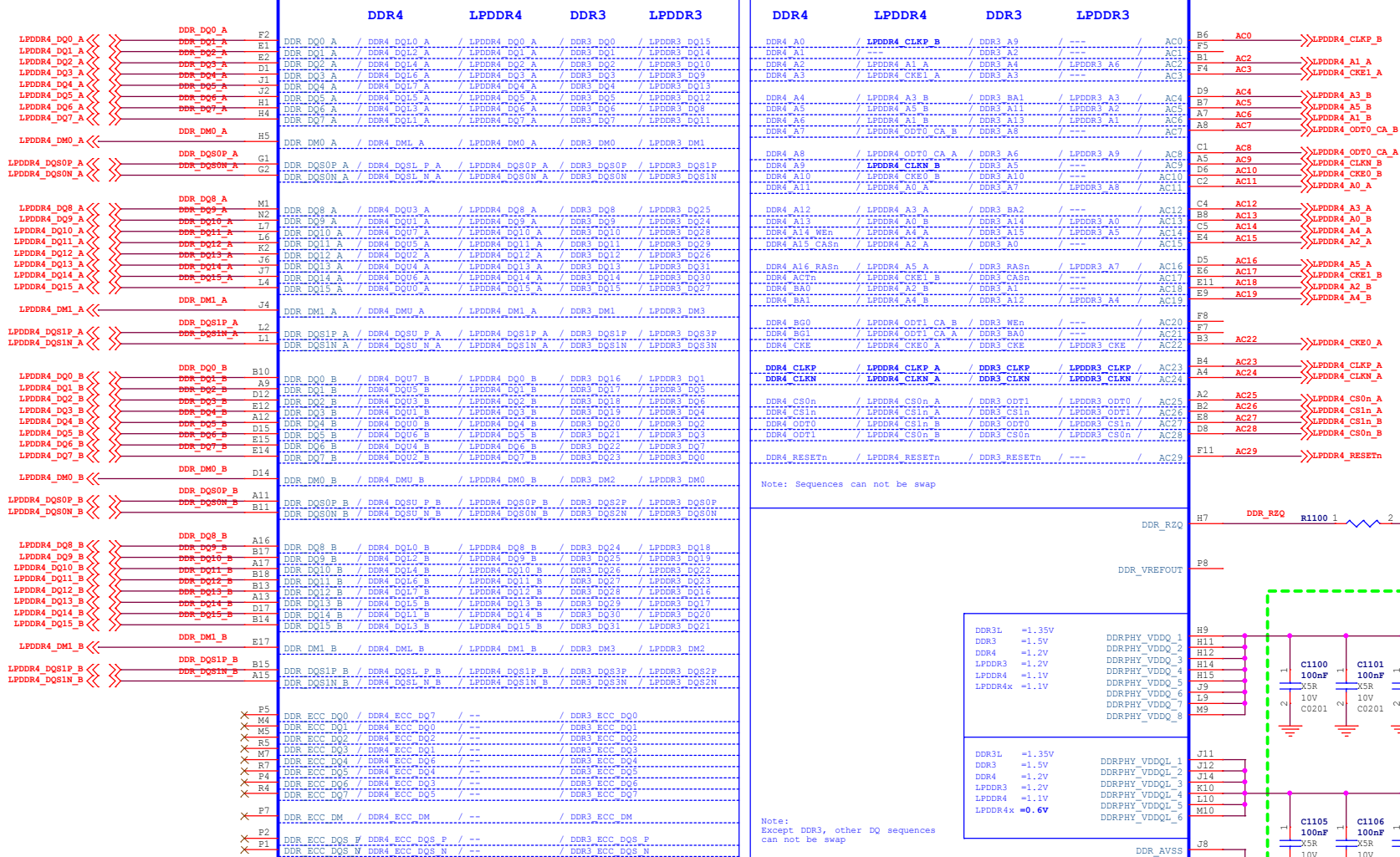

RK3568-Socket
BGA636_65Rx65Rx45Rx3_S

Note: Sequences can not be swap

Note: Except DDR3, other DQ sequences can not be swap

DDR3L	=1.35V	DDRRPHY_VDDQ_1	H9
DDR3	=1.5V	DDRRPHY_VDDQ_2	H11
DDR4	=1.2V	DDRRPHY_VDDQ_3	H12
LPDDR3	=1.2V	DDRRPHY_VDDQ_4	H15
LPDDR4	=1.1V	DDRRPHY_VDDQ_5	J9
LPDDR4x	=1.1V	DDRRPHY_VDDQ_6	L9
		DDRRPHY_VDDQ_7	M9
		DDRRPHY_VDDQ_8	
DDR3L	=1.35V	DDRRPHY_VDDQ_1	J11
DDR3	=1.5V	DDRRPHY_VDDQ_2	J12
DDR4	=1.2V	DDRRPHY_VDDQ_3	J14
LPDDR3	=1.2V	DDRRPHY_VDDQ_4	K10
LPDDR4	=1.1V	DDRRPHY_VDDQ_5	L10
LPDDR4x	=0.6V	DDRRPHY_VDDQ_6	M10

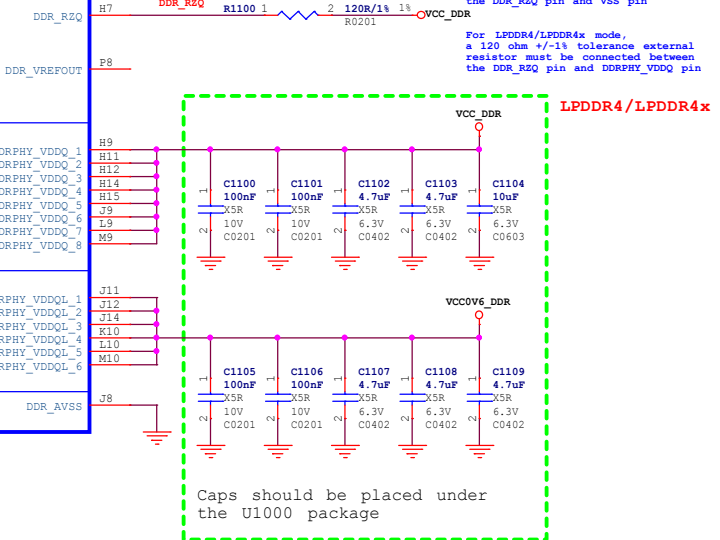

For DDR4/DDR3/LPDDR3 mode, a 120 ohm +/-1% tolerance external resistor must be connected between the DDR_RQ0 pin and VSS pin

For LPDDR4/LPDDR4x mode, a 120 ohm +/-1% tolerance external resistor must be connected between the DDR_RQ0 pin and DDRPHY_VDDQ pin



Title: RK3568 DDR PHY	
File: ROC-3568-PC	REV: V0.1
Create Date: Monday, March 30, 2020	Page Num: 11
Modify Date: Wednesday, May 19, 2021	Page Total: 45

RK3568_G (OSC/PLL/PMUIO1/2)

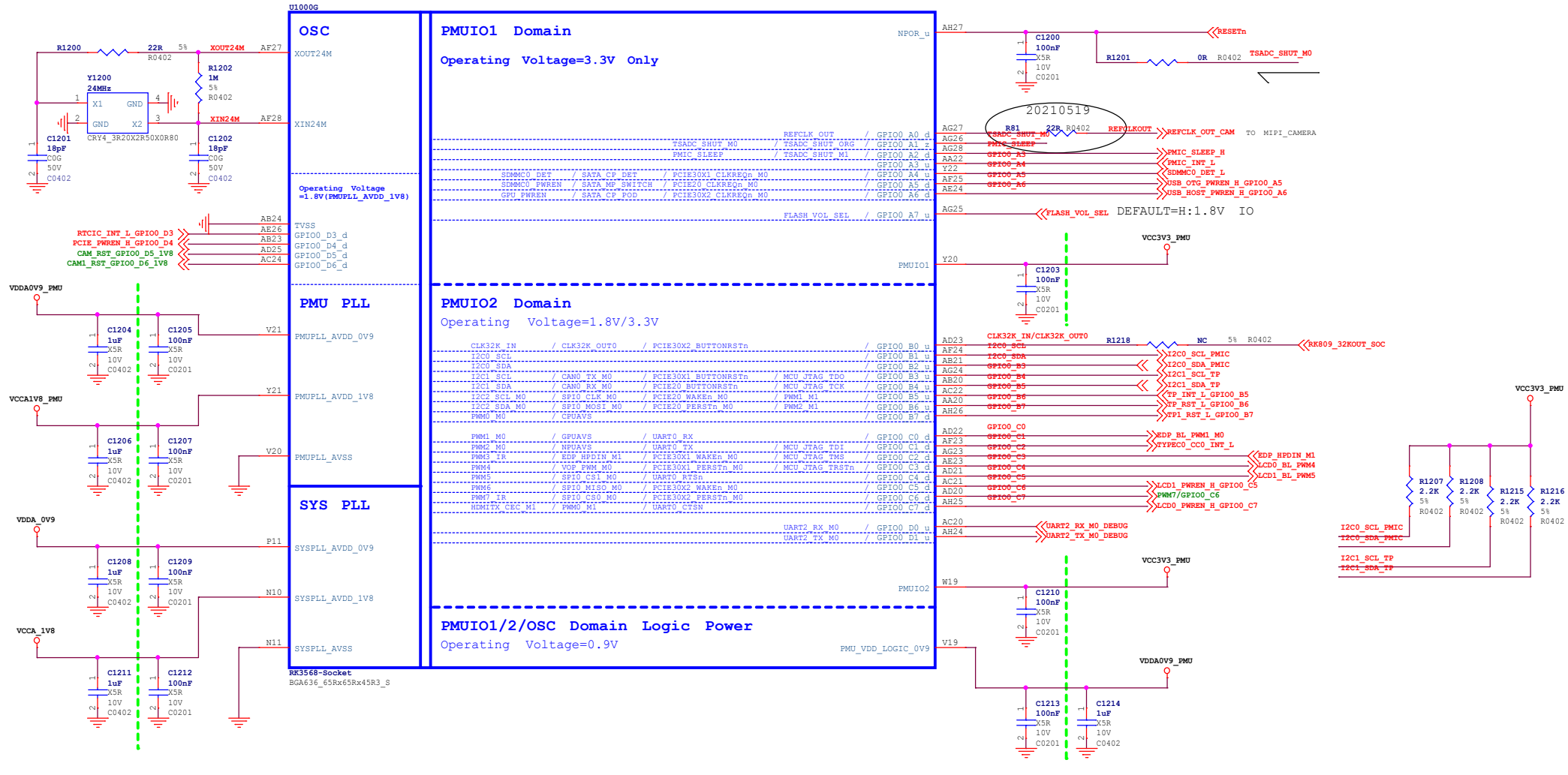

Note:
 Caps of between dashed green lines and U1000 should be placed under the U1000 package.
 Other caps should be placed close to the U1000 package

Rockchip Confidential

 **www.t-firefly.com**

Title: RK3568_OSC/PLL/PMUIO
File: ROC-3568-PC REV: V0.1
Create Date: Monday, March 30, 2020 Page Num: 12
Modify Date: Wednesday, May 19, 2021 Page Total: 45

RK3568_I (VCCIO2 Domain)

U1000I

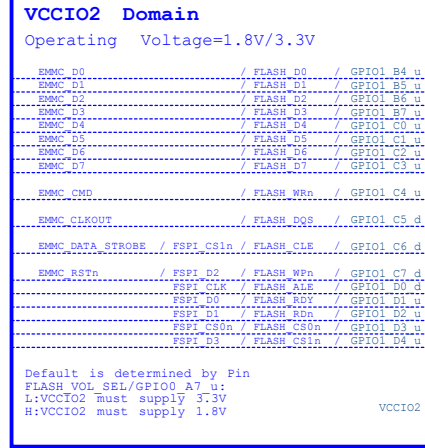

RK3568-Socket
BGA636_65Rx65Rx45R3_S

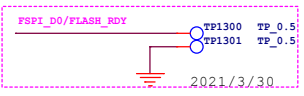
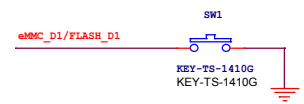

RK3568_J (VCCIO3 Domain)

U1000J

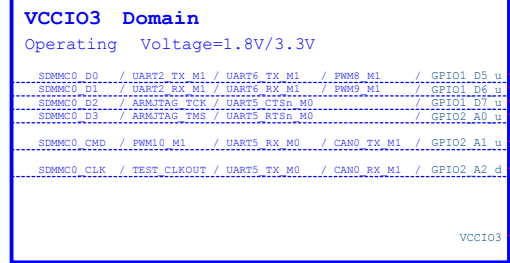

RK3568-Socket
BGA636_65Rx65Rx45R3_S

Note:
Caps of between dashed green lines and U1000 should be placed under the U1000 package



www.t-firefly.com

Title: **RK3568 Flash/SD Controller**
File: **ROC-3568-PC** REV: V0.1
Create Date: Monday, March 30, 2020 Page Num: 13
Modify Date: Wednesday, May 19, 2021 Page Total: 45

RK3568_U (USB3.0/SATA/QSGMII/PCIE2.0 x1)

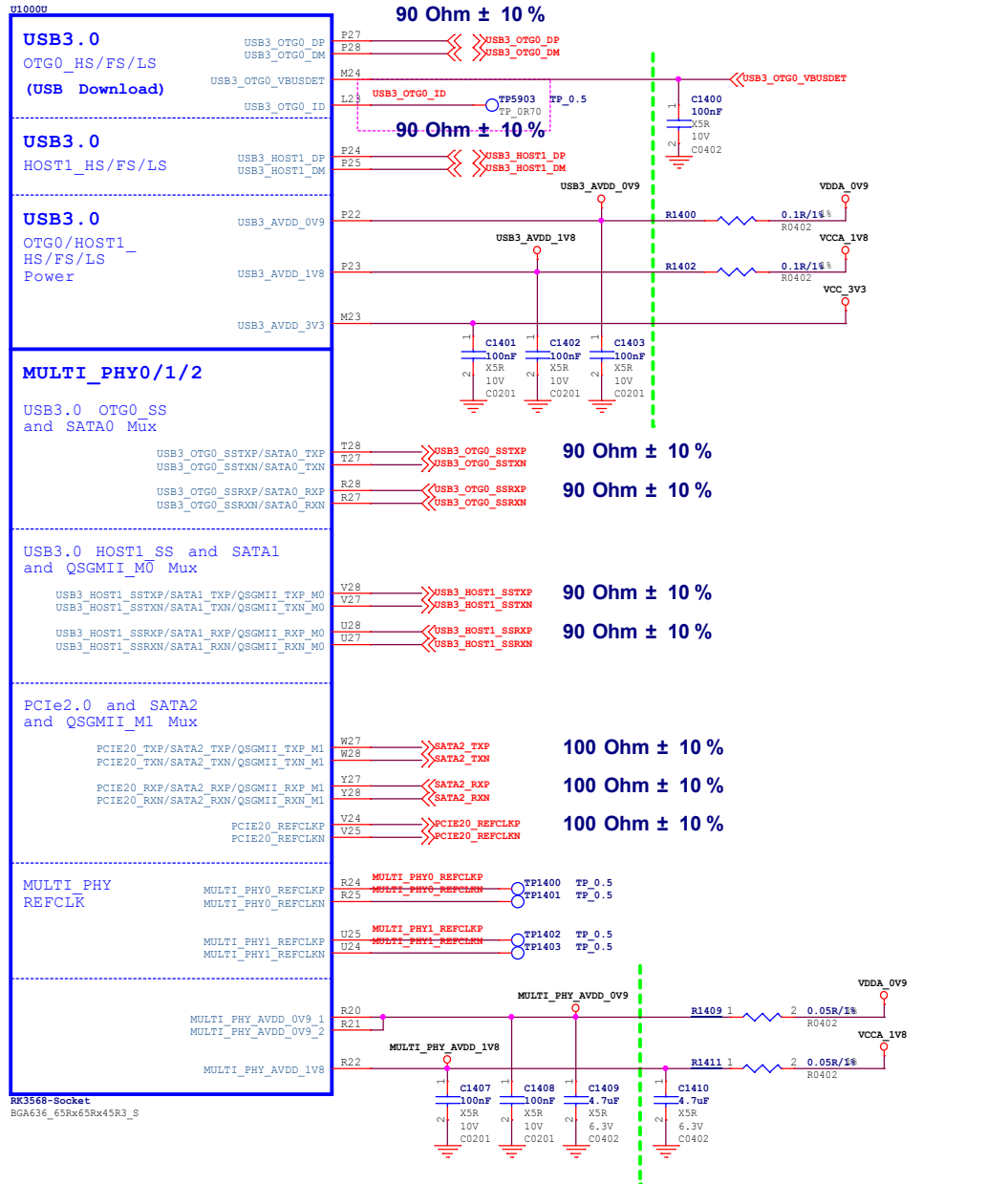

Note:
Caps of between dashed green lines and U1000 should be placed under the U1000 package.
Other caps should be placed close to the U1000 package.

Rockchip Confidential

RK3568_V (USB2.0 HOST)

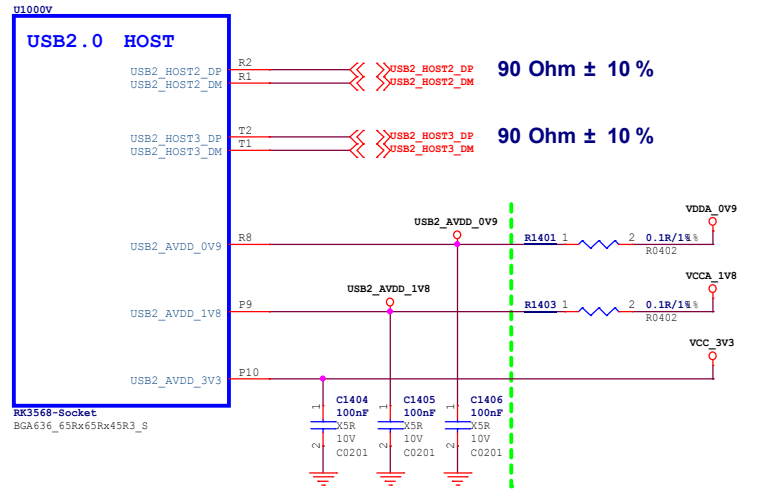

RK3568_W (PCIE3.0 x2)

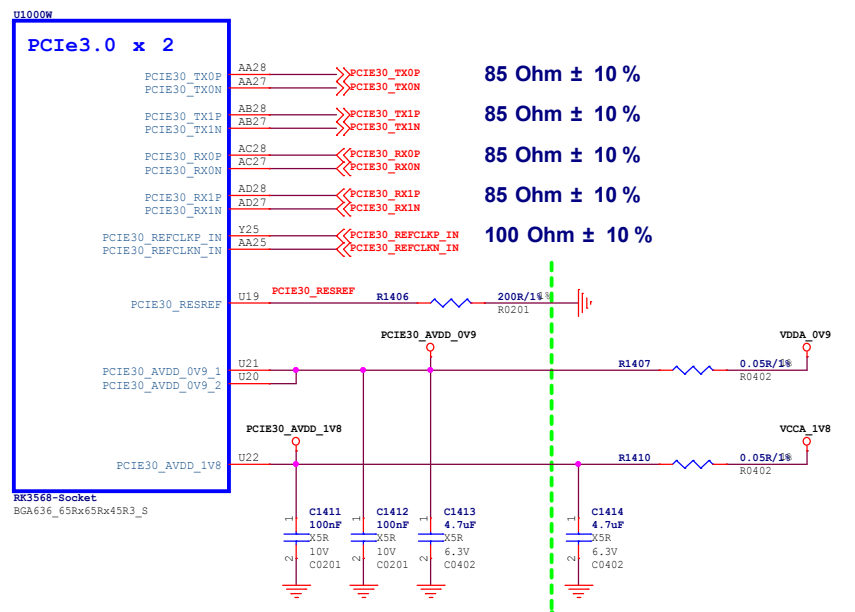

Title: RK3568 USB/PCIE/SATA PHY	
File: ROC-3568-PC	REV: V0.1
Create Date: Monday, March 30, 2020	Page Num: 14
Modify Date: Wednesday, May 19, 2021	Page Total: 45

RK3568_K (VCCIO4 Domain)

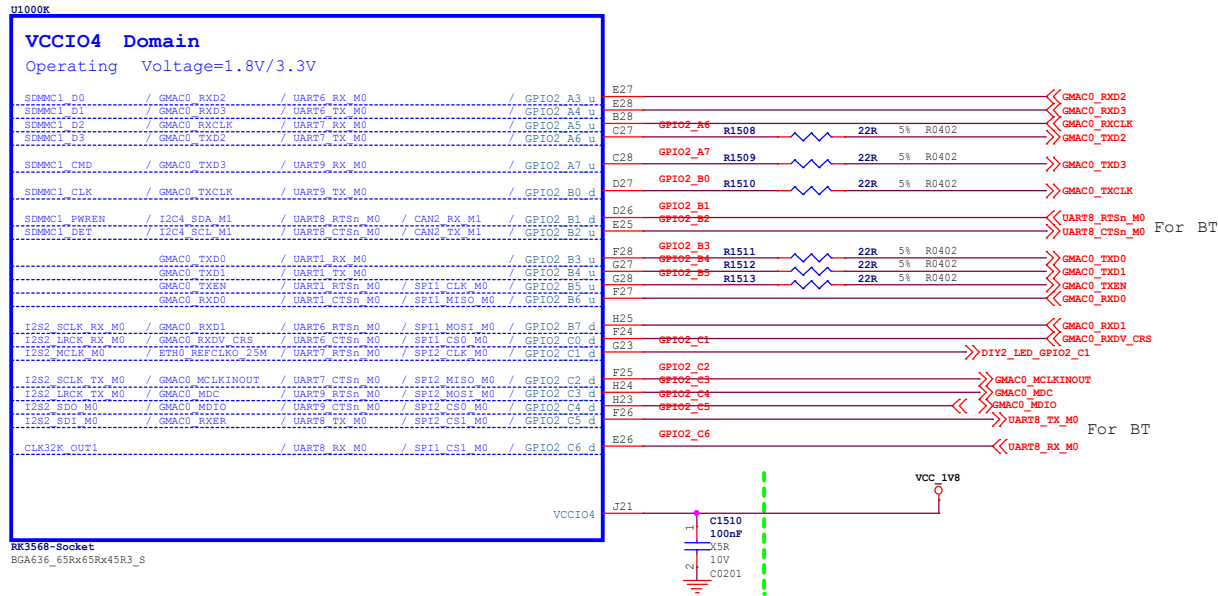

RK3568_N (VCCIO7 Domain)

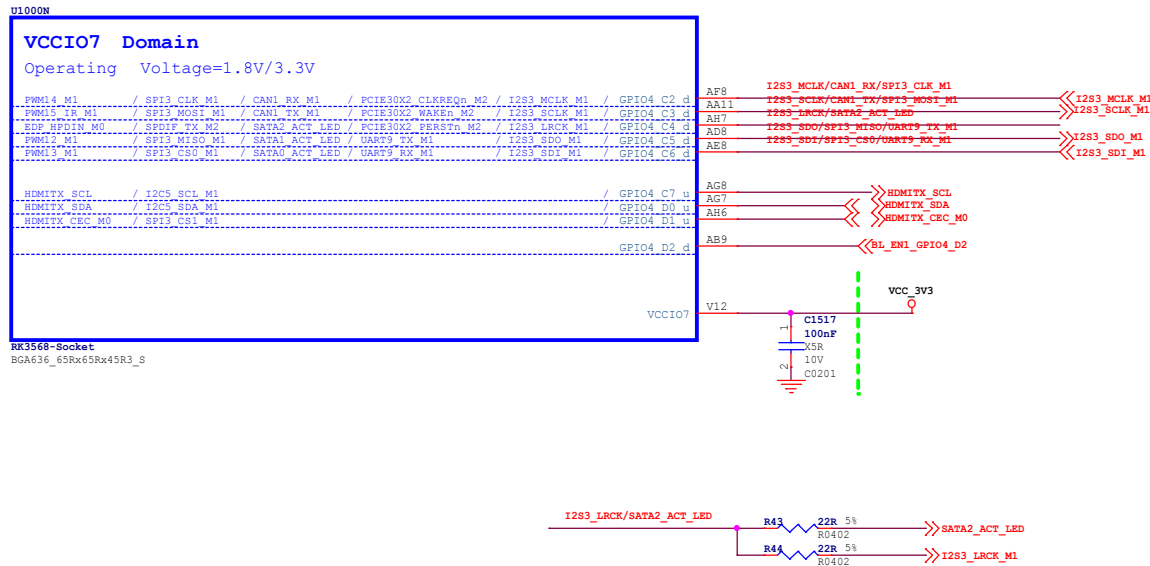

RK3568_O (SARADC/OTP)

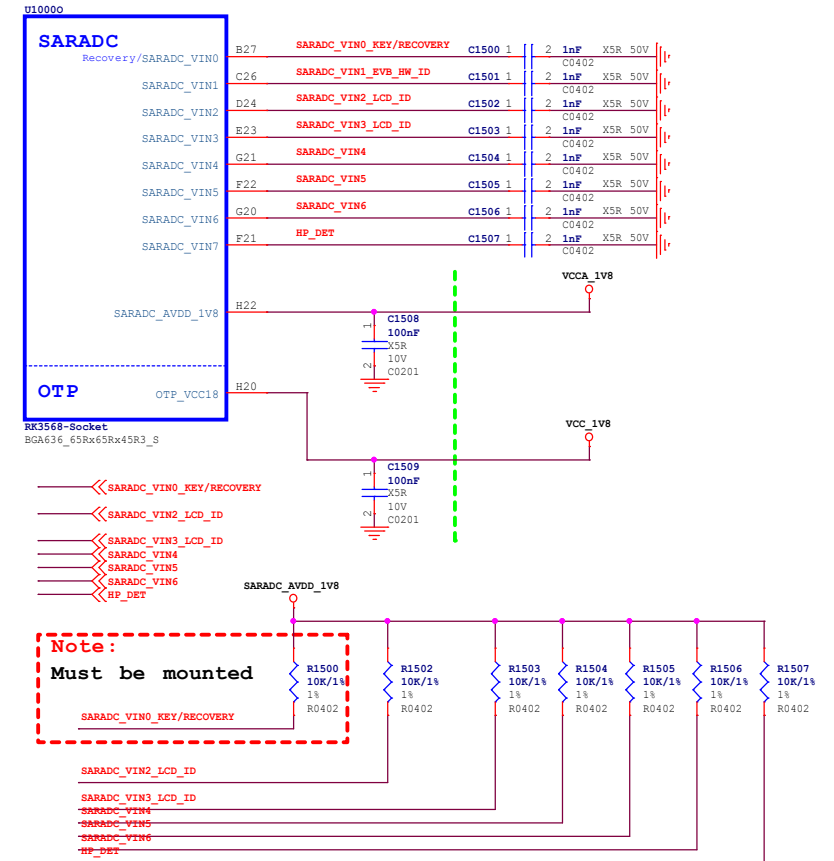

SARADC_VIN1_EVB_HW_ID	Rup	Rdown	ADC	
EVB1	10K	DNP	1023	1.8V
EVB2	20K	100K	852	1.5V
EVB3	18K	36K	681	1.2V
EVB4	51K	51K	512	0.9V
EVB5	36K	18K	340	0.6V
EVB6	100K	20K	170	0.3V
EVB7	DNP	10K	0	0V
EVB8				

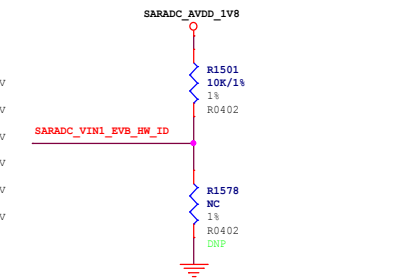

Note:
Caps of between dashed green lines and U1000 should be placed under the U1000 package

www.t-firefly.com

Title: RK3568 SARADC/GPIO
File: ROC-3568-PC
Rev: V0.1

Create Date: Monday, March 30, 2020
Modify Date: Wednesday, May 19, 2021

Page Num: 15
Page Total: 45

RK3568_P(MIPI_CSI_RX)

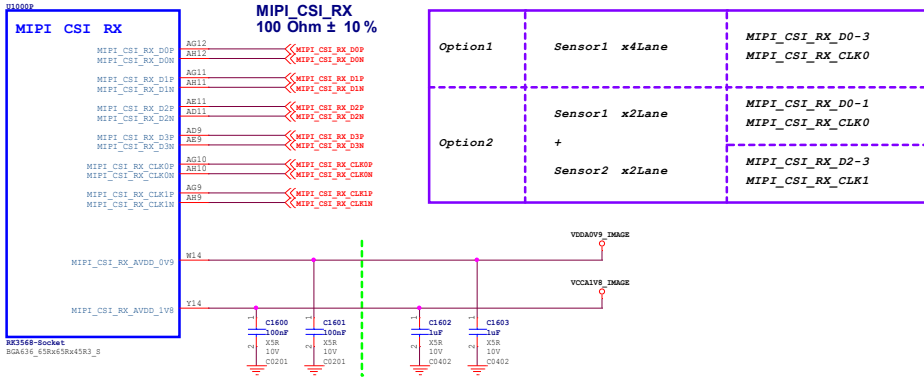

RK3568_M(VCCIO6 Domain)



Mode	16bit	12bit	10bit	8bit
CIF_D0	D0	--	--	--
CIF_D1	D1	--	--	--
CIF_D2	D2	--	--	--
CIF_D3	D3	--	--	--
CIF_D4	D4	D0	--	--
CIF_D5	D5	D1	--	--
CIF_D6	D6	D2	D0	--
CIF_D7	D7	D3	D1	--
CIF_D8	D8	D4	D2	D0
CIF_D9	D9	D5	D3	D1
CIF_D10	D10	D6	D4	D2
CIF_D11	D11	D7	D5	D3
CIF_D12	D12	D8	D6	D4
CIF_D13	D13	D9	D7	D5
CIF_D14	D14	D10	D8	D6
CIF_D15	D15	D11	D9	D7

Support BT601 YCbCr 422 8bit input
 Support BT656 YCbCr 422 8bit input
 Support RAW 8/10/12bit input
 Support BT1120 YCbCr 422 8/10/12/16bit input, single/dual-edge sampling
 Support 2/4 mixed BT656/BT1120 YCbCr 422 8bit input

Note:
 Caps of between dashed green lines and U1000 should be placed under the U1000 package.
 Other caps should be placed close to the U1000 package

www.t-firefly.com

Title: RK3568_VI_Interface

File: ROC-3568-PC

Create Date: Monday, March 30, 2020
 Modify Date: Wednesday, May 19, 2021

REV: V0.1
 Page: 16
 Total: 45

RK3568_R (MIPI_DSI_TX0/LVDS_TX0)

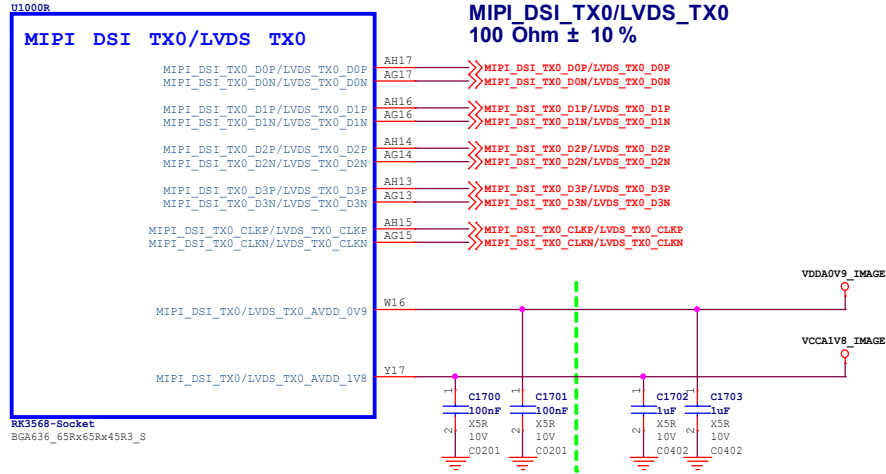

RK3568_S (MIPI_DSI_TX1)

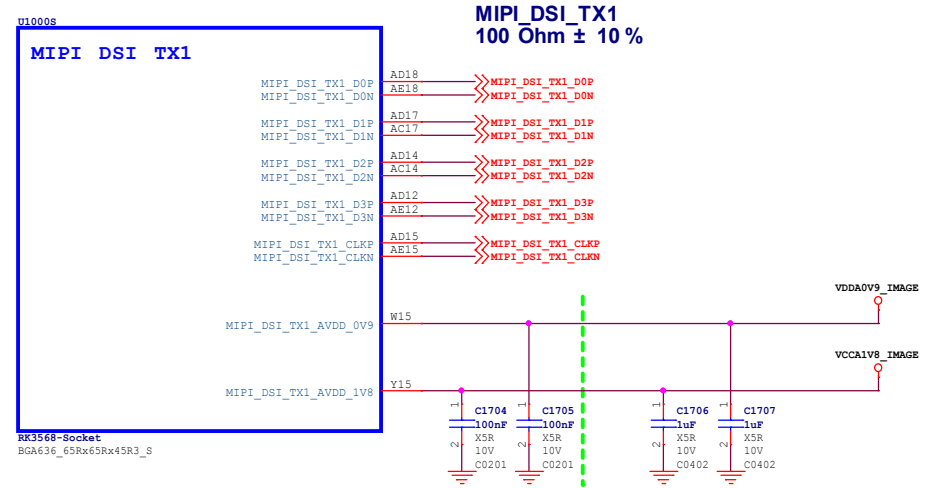

RK3568_T (eDP TX)

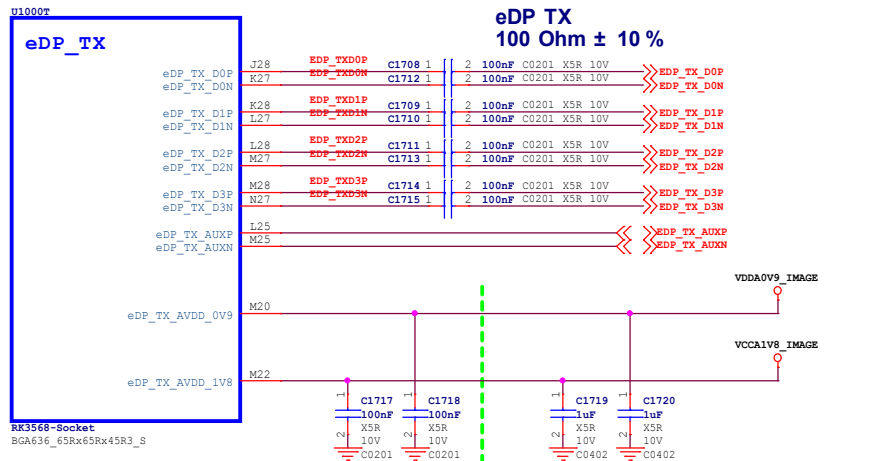

Note:
Caps of between dashed green lines and U1000 should be placed under the U1000 package.
Other caps should be placed close to the U1000 package.

Rockchip Confidential

RK3568_Q (HDMI2.0 TX)

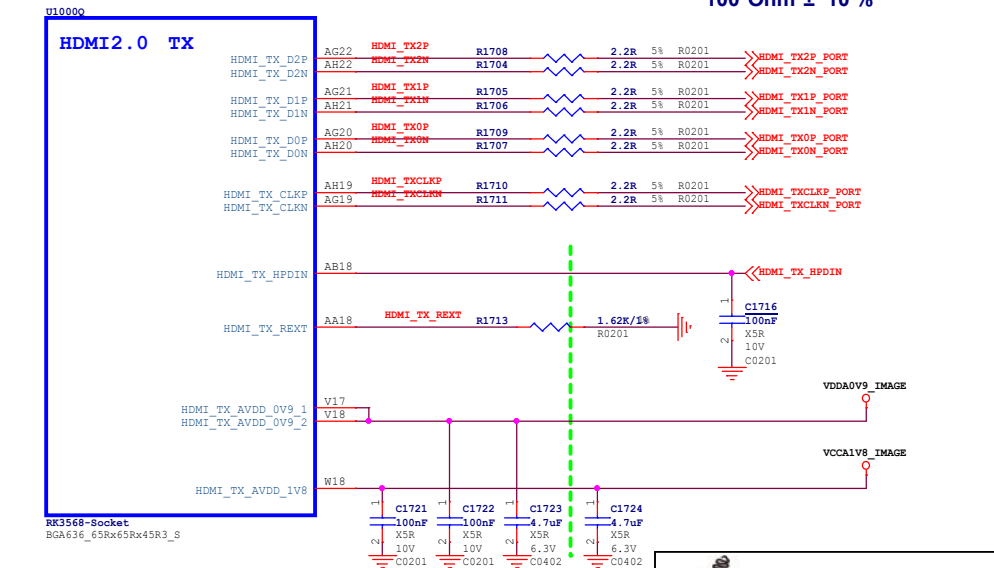

Title: RK3568_V0 Interface 1	
File: ROC-3568-PC	REV: V0.1
Create Date: Monday, March 30, 2020	Page Num: 17
Modify Date: Wednesday, May 19, 2021	Page Total: 45

RK3568_L (VCCIO5 Domain)

U1000L

VCCIO5 Domain

Operating Voltage=1.8V/3.3V

LCDC D0	/ VOP BT656 D0 M0	/ SPI0 MISO M1	/ PCIE20 CLKREQn M1	/ I2S1 MCLK M2	/ GPIO2 D0 d
LCDC D1	/ VOP BT656 D1 M0	/ SPI0 MOSI M1	/ PCIE20 WAKEn M1	/ I2S1 SCLK TX M2	/ GPIO2 D1 d
LCDC D2	/ VOP BT656 D2 M0	/ SPI0 CS0 M1	/ PCIE30X1 CLKREQn M1	/ I2S1 LRCK TX M2	/ GPIO2 D2 d
LCDC D3	/ VOP BT656 D3 M0	/ SPI0 CLK M1	/ PCIE30X1 WAKEn M1	/ I2S1 SDIO M2	/ GPIO2 D3 d
LCDC D4	/ VOP BT656 D4 M0	/ SPI2 CS1 M1	/ PCIE30X2 CLKREQn M1	/ I2S1 SDI1 M2	/ GPIO2 D4 d
LCDC D5	/ VOP BT656 D5 M0	/ SPI2 CS0 M1	/ PCIE30X2 WAKEn M1	/ I2S1 SDI2 M2	/ GPIO2 D5 d
LCDC D6	/ VOP BT656 D6 M0	/ SPI2 MOSI M1	/ PCIE30X2 PERSTn M1	/ I2S1 SDI3 M2	/ GPIO2 D6 d
LCDC D7	/ VOP BT656 D7 M0	/ SPI2 MISO M1	/ UART8 TX M1	/ I2S1 SDO0 M2	/ GPIO2 D7 d
LCDC CLK	/ VOP BT656 CLK M0	/ SPI2 CLK M1	/ UART8 RX M1	/ I2S1 SDO1 M2	/ GPIO3 A0 d
LCDC D8	/ VOP BT1120 D0	/ SPI1 CS0 M1	/ PCIE30X1 PERSTn M1	/ SDMMC2 D0 M1	/ GPIO3 A1 d
LCDC D9	/ VOP BT1120 D1	/ GMAC1 TXD2 M0	/ I2S3 MCLK M0	/ SDMMC2 D1 M1	/ GPIO3 A2 d
LCDC D10	/ VOP BT1120 D2	/ GMAC1 TXD3 M0	/ I2S3 SCLK M0	/ SDMMC2 D2 M1	/ GPIO3 A3 d
LCDC D11	/ VOP BT1120 D3	/ GMAC1 RXD2 M0	/ I2S3 LRCK M0	/ SDMMC2 D3 M1	/ GPIO3 A4 d
LCDC D12	/ VOP BT1120 D4	/ GMAC1 RXD3 M0	/ I2S3 SDO M0	/ SDMMC2 CMD M1	/ GPIO3 A5 d
LCDC D13	/ VOP BT1120 CLK	/ GMAC1 TXCLK M0	/ I2S3 SDI M0	/ SDMMC2 CLK M1	/ GPIO3 A6 d
LCDC D14	/ VOP BT1120 D5	/ GMAC1 RXCLK M0	/ SDMMC2 DET M1	/ GPIO3 A7 d	
LCDC D15	/ VOP BT1120 D6	/ ETH1 REFCLK0 25M M0	/ SDMMC2 PWREN M1	/ GPIO3 B0 d	
LCDC D16	/ VOP BT1120 D7	/ GMAC1 RXD0 M0	/ UART4 RX M1	/ PWM8 M0	/ GPIO3 B1 d
LCDC D17	/ VOP BT1120 D8	/ GMAC1 RXD1 M0	/ UART4 TX M1	/ PWM9 M0	/ GPIO3 B2 d
LCDC D18	/ VOP BT1120 D9	/ GMAC1 RXDV CRS M0	/ I2C5 SCL M0	/ PDM SDI0 M2	/ GPIO3 B3 d
LCDC D19	/ VOP BT1120 D10	/ GMAC1 RXER M0	/ I2C5 SDA M0	/ PDM SDI1 M2	/ GPIO3 B4 d
LCDC D20	/ VOP BT1120 D11	/ GMAC1 TXD0 M0	/ I2C3 SCL M1	/ PWM10 M0	/ GPIO3 B5 d
LCDC D21	/ VOP BT1120 D12	/ GMAC1 TXD1 M0	/ I2C3 SDA M1	/ PWM11 IR M0	/ GPIO3 B6 d
LCDC D22	/ PWM12 M0	/ GMAC1 TXEN M0	/ UART3 TX M1	/ PDM SDI2 M2	/ GPIO3 B7 d
LCDC D23	/ PWM13 M0	/ GMAC1 MCLKINOUT M0	/ UART3 RX M1	/ PDM SDI3 M2	/ GPIO3 C0 d
LCDC HSYNC	/ VOP BT1120 D13	/ SPI1 MOSI M1	/ PCIE20 PERSTn M1	/ I2S1 SDO2 M2	/ GPIO3 C1 d
LCDC VSYNC	/ VOP BT1120 D14	/ SPI1 MISO M1	/ UART5 TX M1	/ I2S1 SDO3 M2	/ GPIO3 C2 d
LCDC DEN	/ VOP BT1120 D15	/ SPI1 CLK M1	/ UART5 RX M1	/ I2S1 SCLK RX M2	/ GPIO3 C3 d
PWM14 M0	/ VOP PWM M1	/ GMAC1 MDC M0	/ UART7 TX M1	/ PDM CLK1 M2	/ GPIO3 C4 d
PWM15 IR M0	/ SPDIF TX M1	/ GMAC1 MDIO M0	/ UART7 RX M1	/ I2S1 LRCK RX M2	/ GPIO3 C5 d

RK3568-Socket
BGA636_65Rx65Rx45R3_S

VCCIO5_1
VCCIO5_2

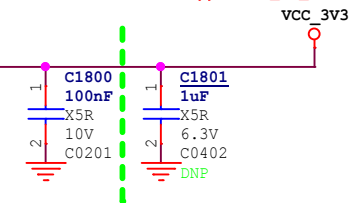
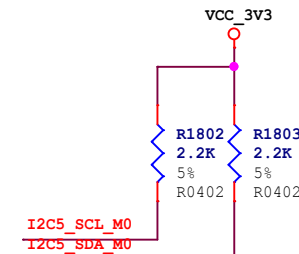
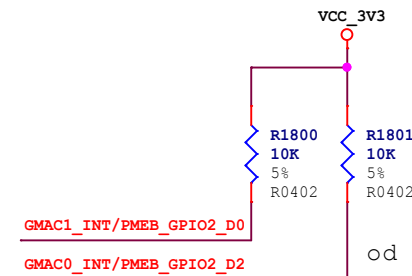
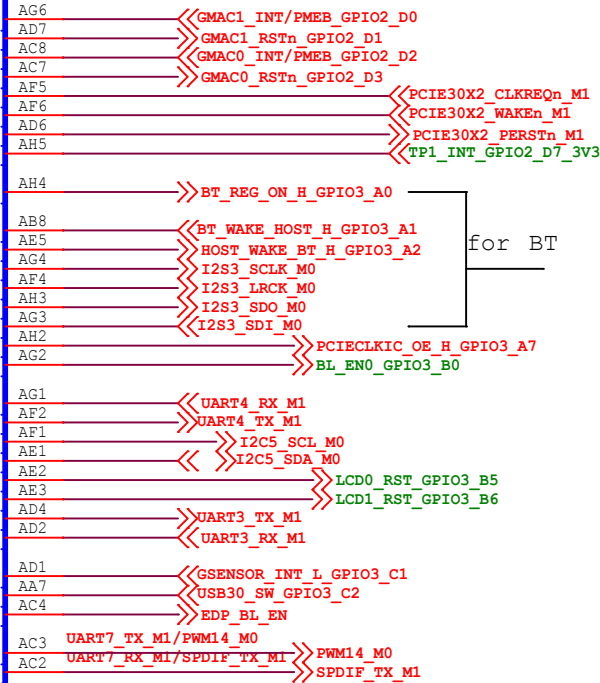

Note:
Caps of between dashed green lines and U1000 should be placed under the U1000 package

Rockchip Confidential



www.t-firefly.com

Title: RK3568 VO Interface 2	
File: ROC-3568-PC	REV: VO.1
Create Date: Wednesday, May 06, 2020	Page Num: 18
Modify Date: Wednesday, May 19, 2021	Page Total: 45

12V/3A DCIN

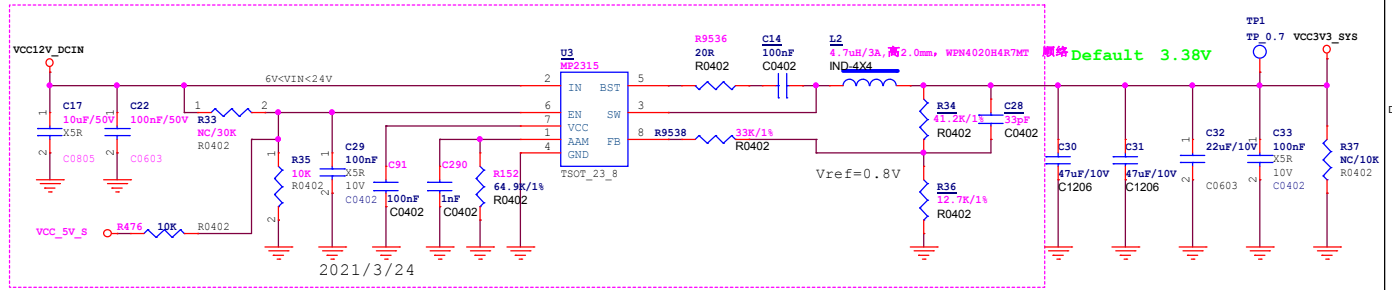
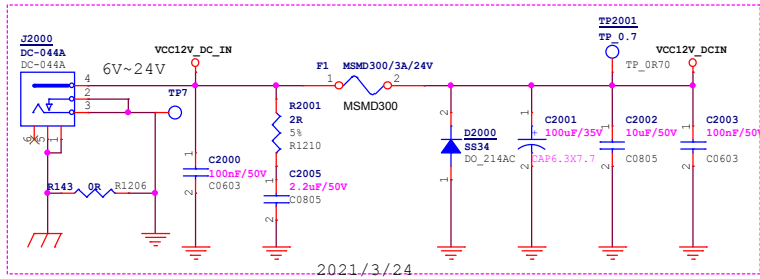

VCC3V3_SYS

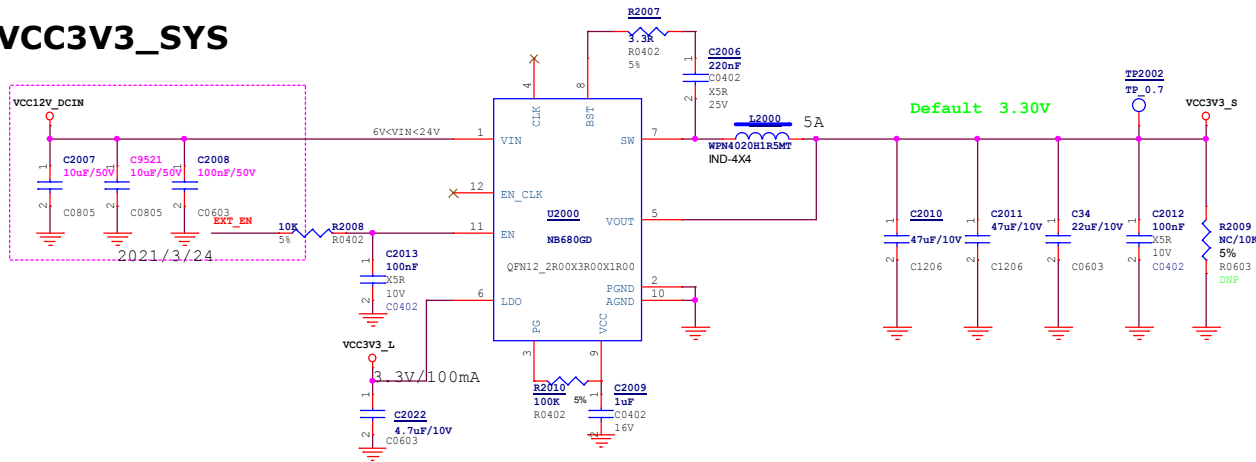

VCC5V0_SYS

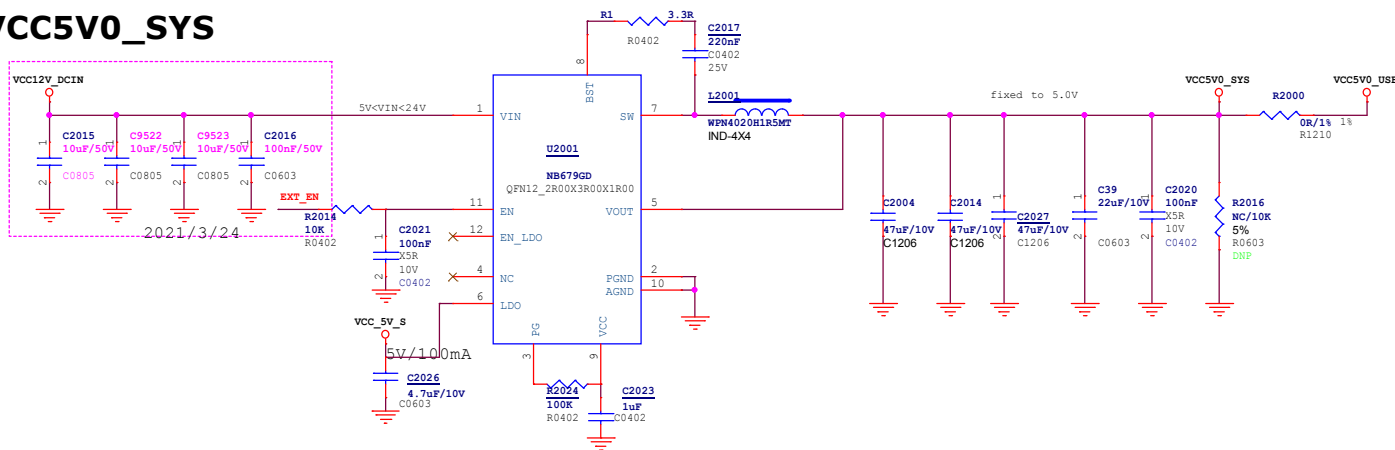

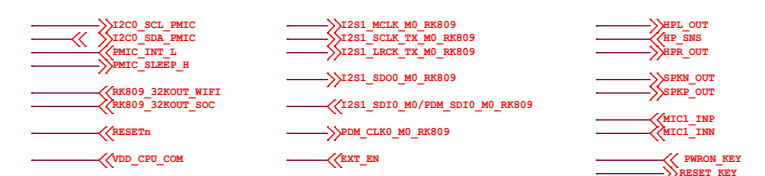

www.t-firefly.com

Title: Power DC IN		REV: V0.1
File: ROC-3568-PC		
Create Date: Monday, May 18, 2020	Page Num: 20	
Modify Date: Wednesday, May 19, 2021	Page Total: 45	

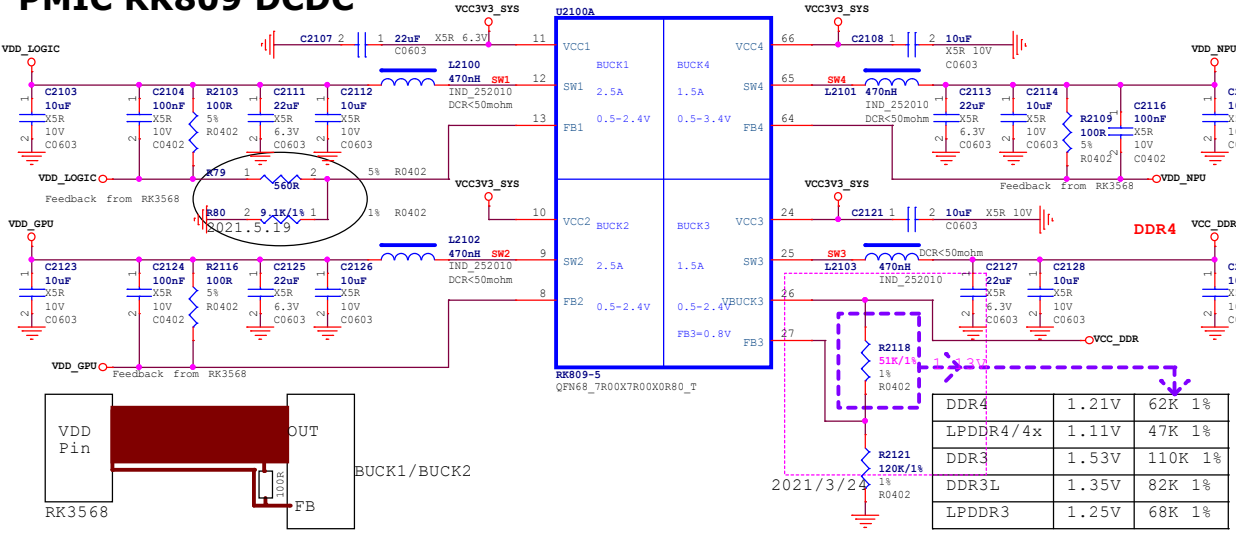

PMIC RK809 DCDC



PMIC RK809 LDO

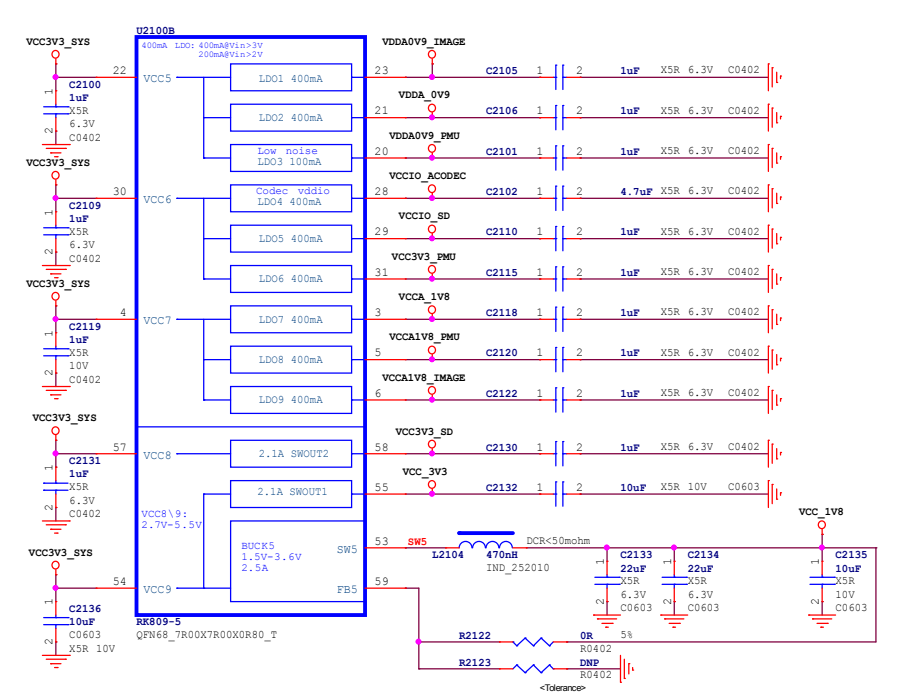

PMIC RK809 Management

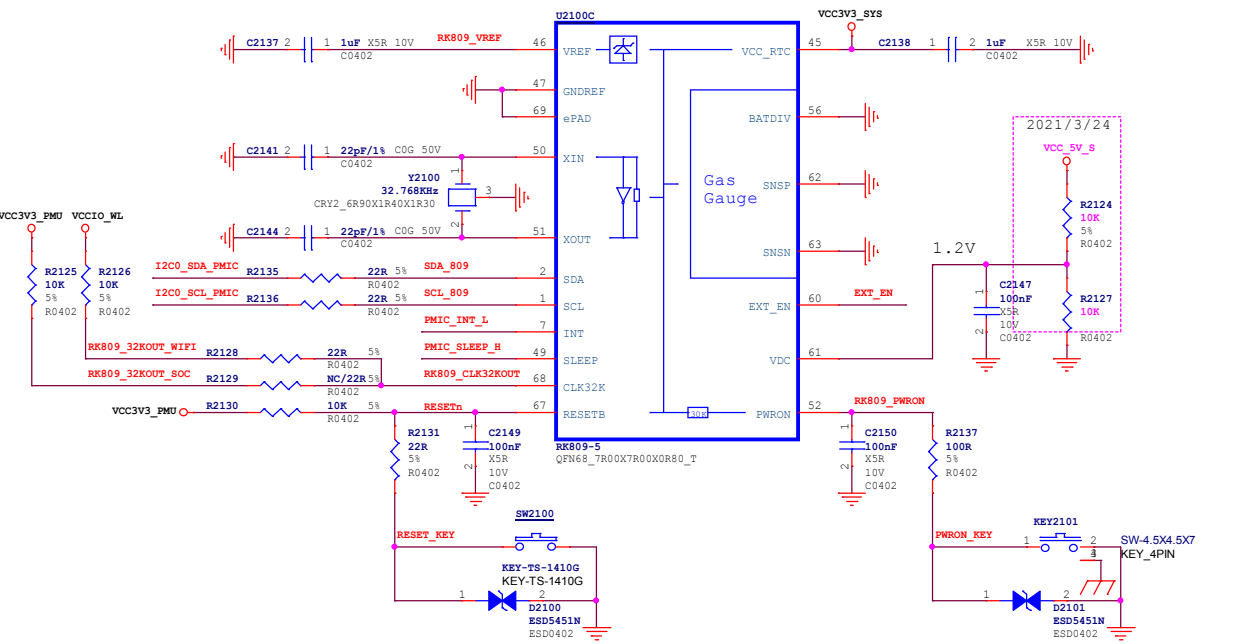

PMIC RK809 CODEC

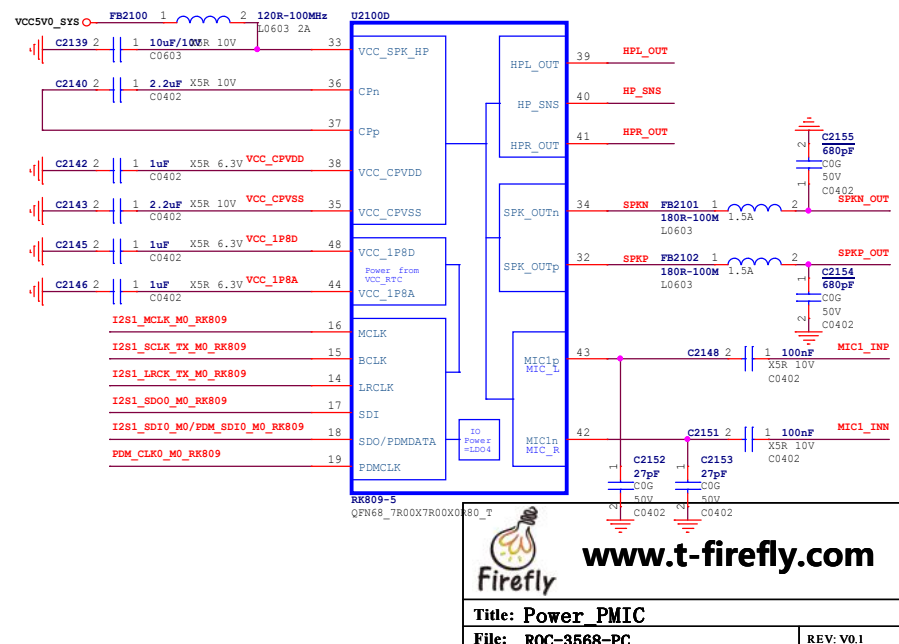

Rockchip Confidential

www.t-firefly.com

Firefly

Title: Power PMIC

File: ROC-3568-PC

REV: V0.1

Create Date: Monday, May 18, 2020

Page Num: 21

Modify Date: Wednesday, May 19, 2021

Page Total: 45

>>>PWRON_KEY <<<RTCIC_INT_L_GPI00_D3
 >>>VDD_CPU_COM <<<I2C0_SCL_FM1C <<<I2C5_SCL_M0
 <<<I2C0_SDA_FM1C <<<I2C5_SDA_M0

VDD_CPU

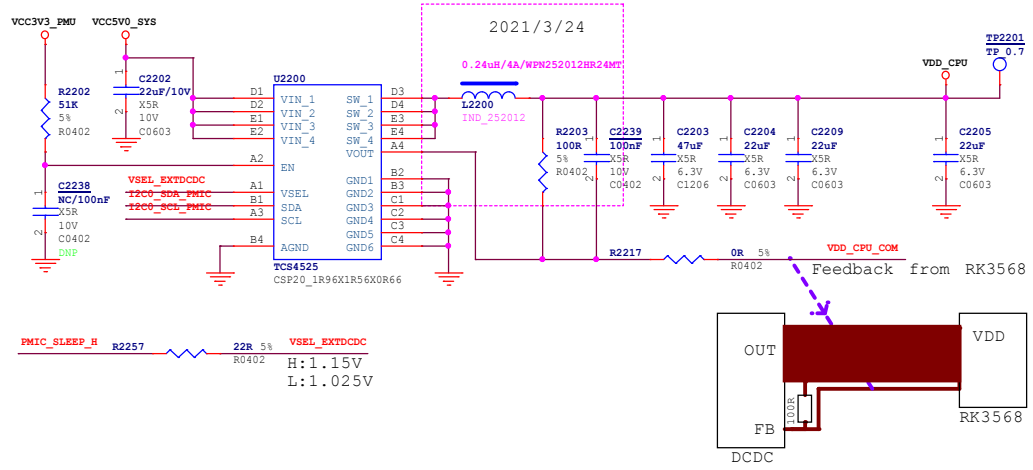

RTC IC

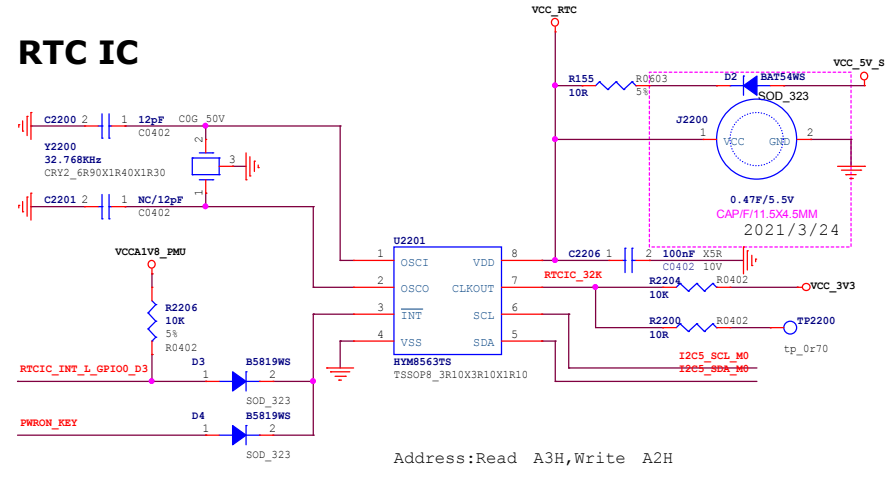



www.t-firefly.com
Title: Power_other
File: ROC-3568-PC REV: V0.1
 Create Date: Monday, May 18, 2020 Page Num: 22
 Modify Date: Wednesday, May 19, 2021 Page Total: 45

Flash Power Manage

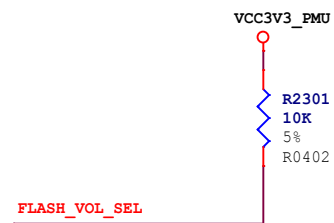
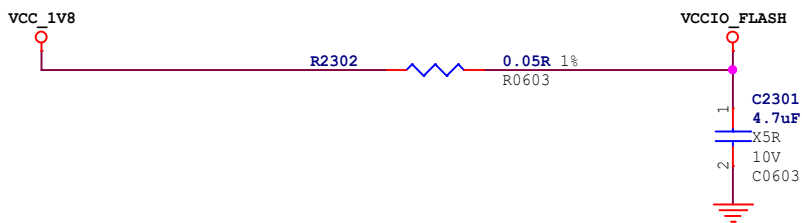
	VCCIO2 domain voltage: Recommend voltage value (VCCIO_FLASH)	FLASH_VOL_SEL state decided to VCCIO2 domain IO driven by default
eMMC	1.8V	FLASH_VOL_SEL --> Logic=H
Nand flash	Default 3.3V, Adjust according to demand 1.8V	FLASH_VOL_SEL --> Logic=L(Default)
SPI flash	Default 3.3V, Adjust according to demand 1.8V	FLASH_VOL_SEL --> Logic=L(Default)



Note:
 FLASH VOL SEL state decided
 to VCCIO2 domain IO driven by default
 Logic=L:3.3V IO driven
 Logic=H:1.8V IO driven



www.t-firefly.com

Title: Power Flash Power Manage

File: ROC-3568-PC REV: V0.1

Create Date: Tuesday, May 19, 2020	Page Num: 23
Modify Date: Wednesday, May 19, 2021	Page Total: 45

USB3_HOST1_DP
 USB3_HOST1_DM
 USB3_HOST1_SSTX0
 USB3_HOST1_SSTX1
 USB3_HOST1_SSRX0
 USB3_HOST1_SSRX1

USB2_HOST2_DP
 USB2_HOST2_DM

USB_HOST_DM1
 USB_HOST_DP1

USB_HOST_PWREN_H_CP100_A6

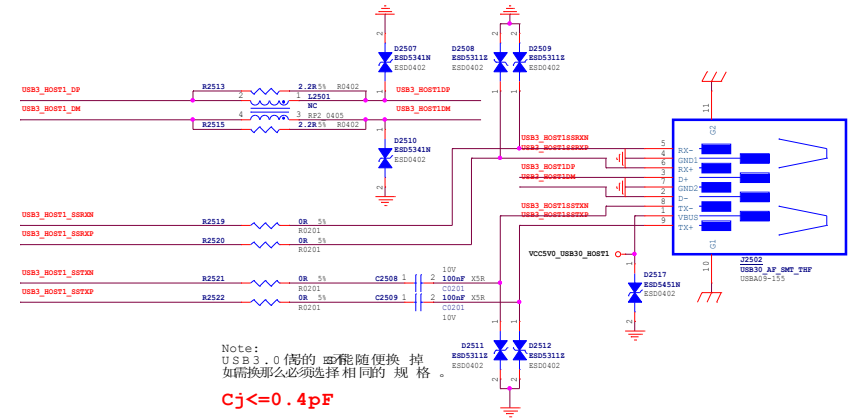
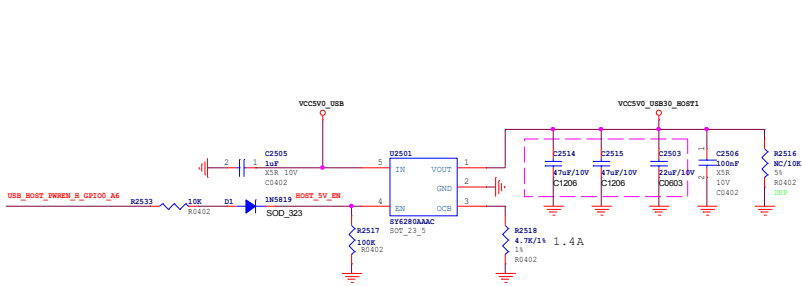

USB3.0 HOST1

Note:
USB 3.0 偏置的电容随便换掉
如需换那么必须选择相同的规格。

$$Cj \leq 0.4 \text{ pF}$$

USB2.0 HOST2
USB2.0 HOST3

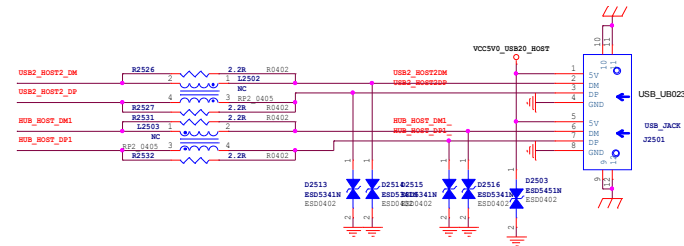
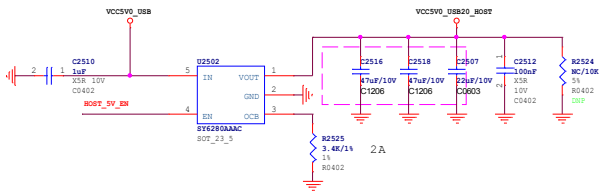

USB2.0 HUB

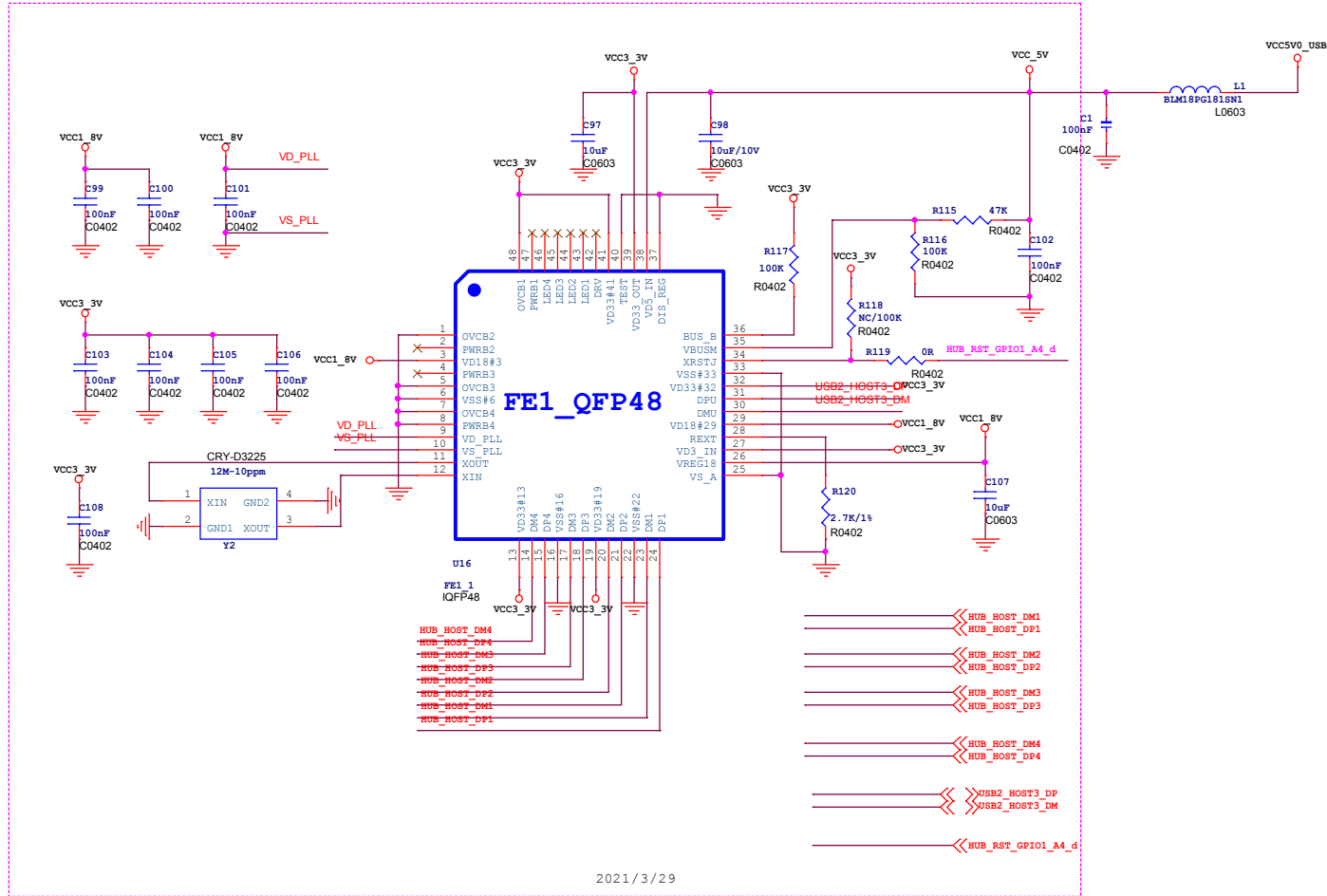

DEBUG

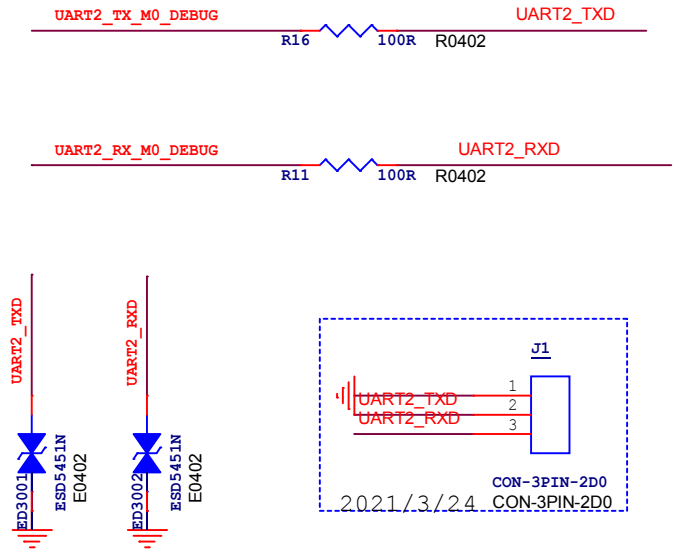

KEY

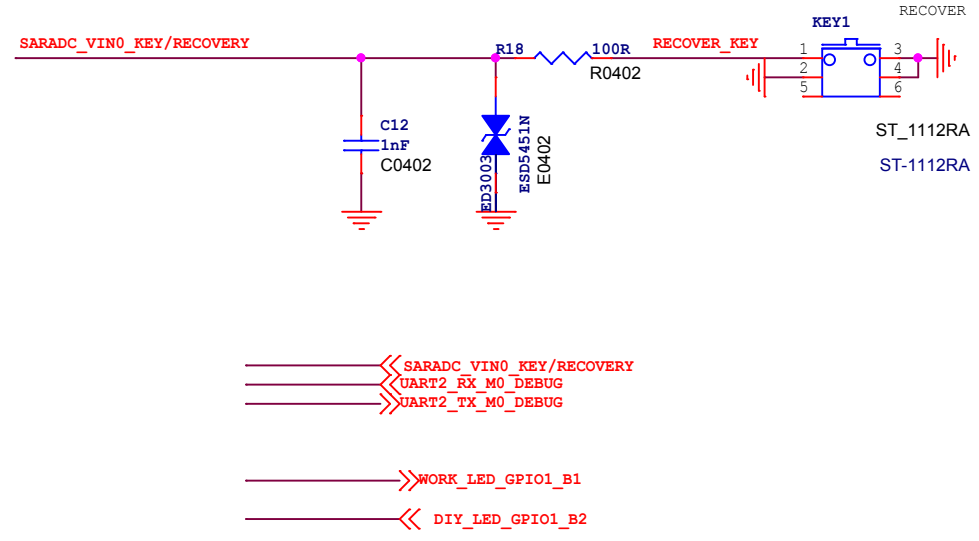

LED

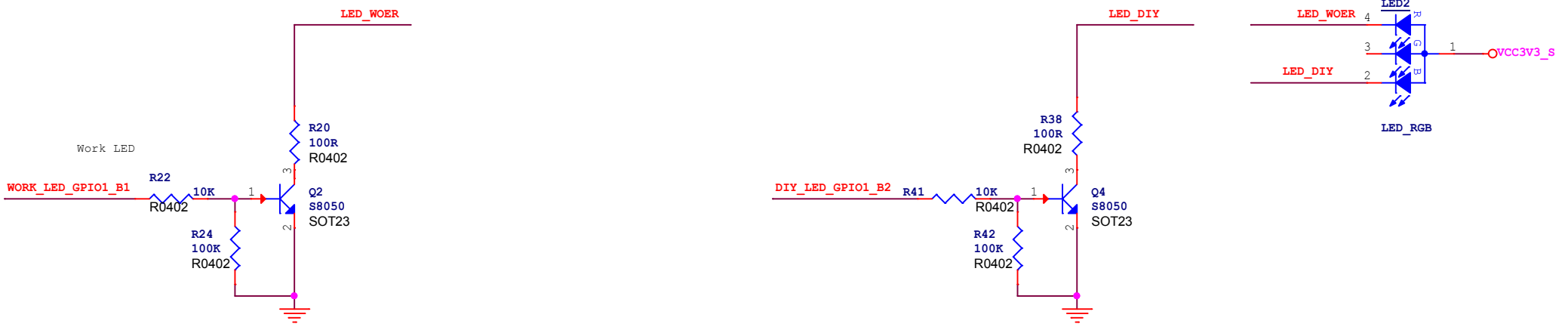



www.t-firefly.com

Title: KEY/LED/DEBUG	
File: ROC-3568-PC	REV: V0.1
Create Date: Wednesday, November 04, 2020	Page Num: 26
Modify Date: Wednesday, May 19, 2021	Page Total: 45

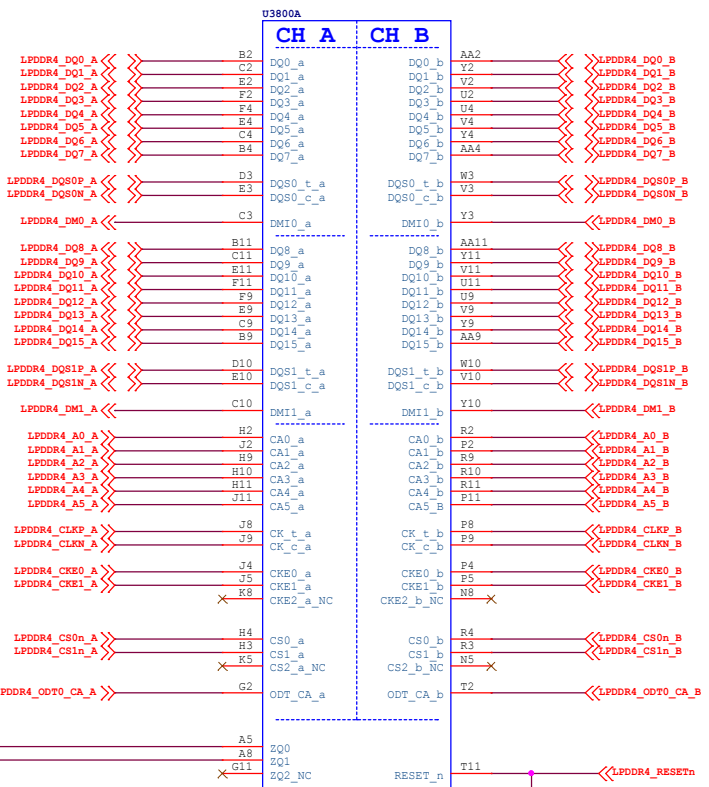

LPDDR4: MT53D512M32D2S-053 WT:D (D9WHZ) (3733)
 LPDDR4x: Hynix H9HCNNNBKMLHR-NME (3733)

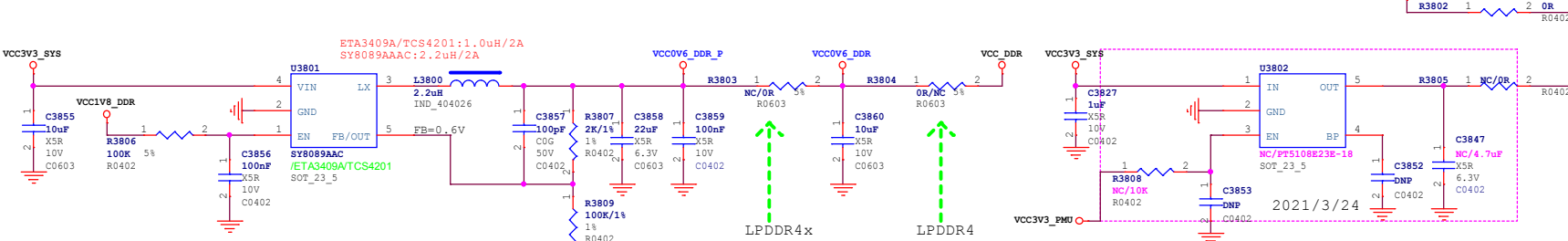
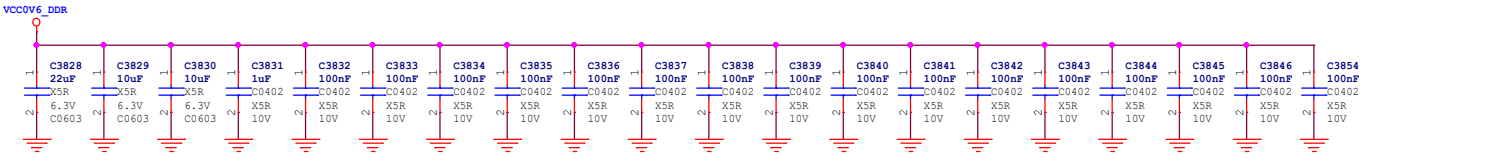
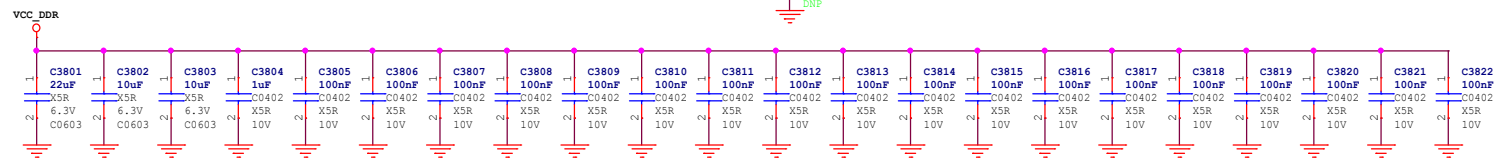
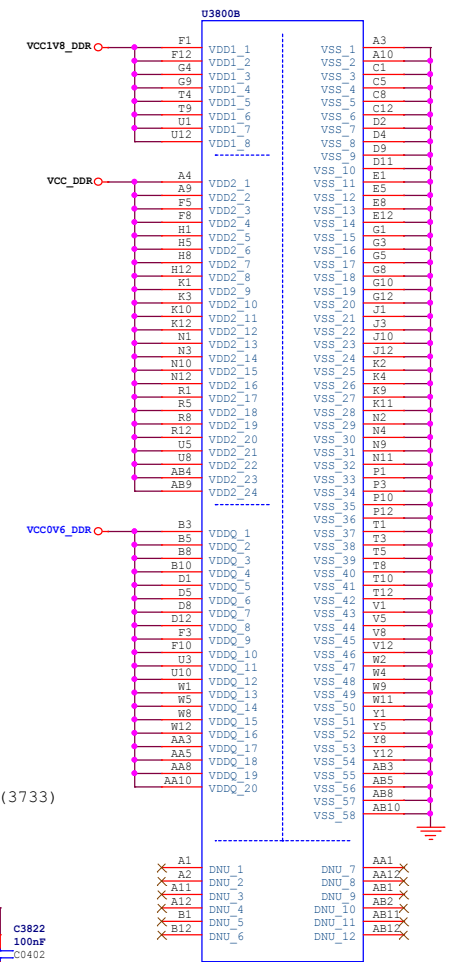

Firefly www.t-firefly.com

Title: DRAM-LPDDR4X 1X32bit 200P

File: ROC-3668-PC REV: V0.1

Create Date: Thursday, January 14, 2021 Page Num: 27

Modify Date: Wednesday, May 19, 2021 Page Total: 45

Rockchip Confidential

LPDDR4 不翻破龙的

- >>eMMC_D0/FLASH_D0
- >>eMMC_D1/FLASH_D1
- >>eMMC_D2/FLASH_D2
- >>eMMC_D3/FLASH_D3
- >>eMMC_D4/FLASH_D4
- >>eMMC_D5/FLASH_D5
- >>eMMC_D6/FLASH_D6
- >>eMMC_D7/FLASH_D7

- >>eMMC_CMD/FLASH_WRn

- >>eMMC_CLKOUT/FLASH_DQS

- >>eMMC_DATA_STROBE/FLASH_CLE

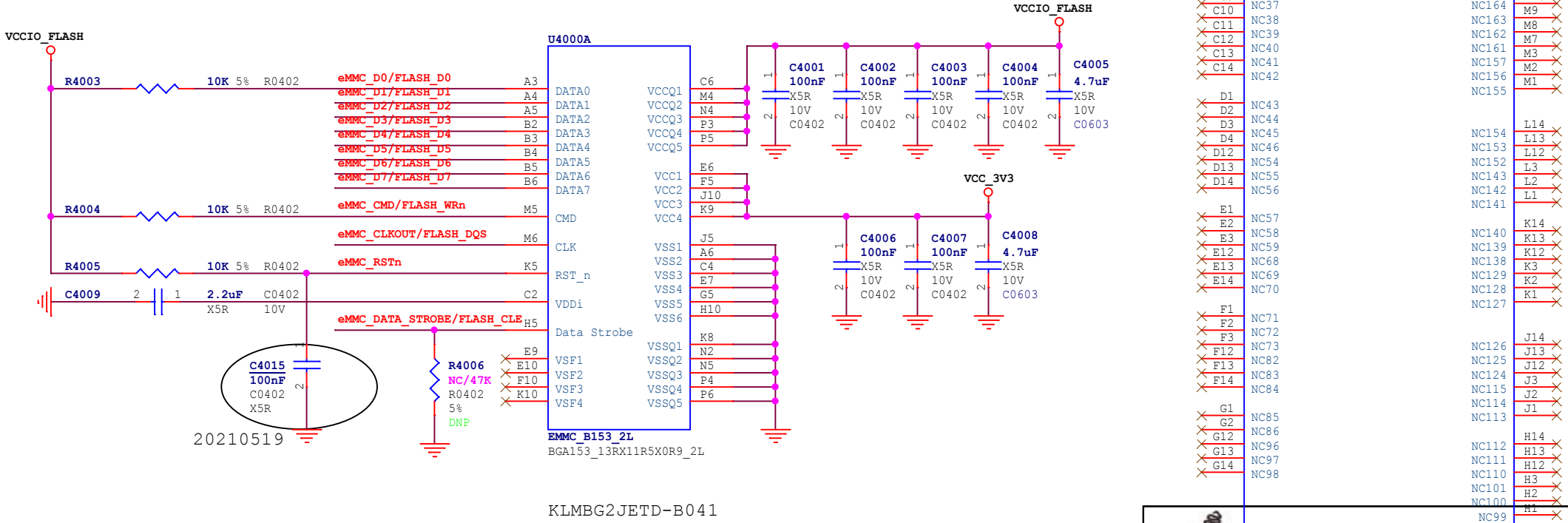

U4000B		U4000A	
A2	NC2	A3	eMMC_D0/FLASH_D0
A8	NC8	A4	eMMC_D1/FLASH_D1
A9	NC9	A5	eMMC_D2/FLASH_D2
A10	NC10	A6	eMMC_D3/FLASH_D3
A11	NC11	B2	eMMC_D4/FLASH_D4
A12	NC12	B3	eMMC_D5/FLASH_D5
A13	NC13	B4	eMMC_D6/FLASH_D6
A14	NC14	B5	eMMC_D7/FLASH_D7
B1	NC15	B6	eMMC_CMD/FLASH_WRn
B7	NC21	M5	eMMC_CLKOUT/FLASH_DQS
B8	NC22	M6	eMMC_RSTn
B9	NC23	K5	eMMC_DATA_STROBE/FLASH_CLE
B10	NC24	C2	VDDi
B11	NC25	H5	Data Strobe
B12	NC26	E9	VSF1
B13	NC27	E10	VSF2
B14	NC28	F10	VSF3
C1	NC29	K10	VSF4
C3	NC31	E9	VSSQ1
C7	NC35	E10	VSSQ2
C8	NC36	F10	VSSQ3
C9	NC37	K10	VSSQ4
C10	NC38	K10	VSSQ5
C11	NC39	E9	VSS1
C12	NC40	E10	VSS2
C13	NC41	F10	VSS3
C14	NC42	K10	VSS4
D1	NC43	E9	VSS5
D2	NC44	E10	VSS6
D3	NC45	F10	VSSQ1
D4	NC46	K10	VSSQ2
D12	NC54	E9	VSSQ3
D13	NC55	E10	VSSQ4
D14	NC56	F10	VSSQ5
E1	NC57	K10	VSS1
E2	NC58	E9	VSS2
E3	NC59	E10	VSS3
E12	NC68	F10	VSS4
E13	NC69	K10	VSS5
E14	NC70	E9	VSS6
F1	NC71	E10	VSSQ1
F2	NC72	F10	VSSQ2
F3	NC73	K10	VSSQ3
F12	NC82	E9	VSSQ4
F13	NC83	E10	VSSQ5
F14	NC84	F10	VSS1
G1	NC85	K10	VSS2
G2	NC86	E9	VSS3
G12	NC96	E10	VSS4
G13	NC97	F10	VSS5
G14	NC98	K10	VSS6
A7	REFU1	A7	REFU1
B5	REFU2	B5	REFU2
F8	REFU3	F8	REFU3
G3	REFU4	G3	REFU4
G10	REFU5	G10	REFU5
K6	REFU6	K6	REFU6
F7	REFU7	F7	REFU7
F10	REFU8	F10	REFU8
F10	REFU9	F10	REFU9
P14	NC196	P14	NC196
P13	NC195	P13	NC195
P12	NC194	P12	NC194
P11	NC193	P11	NC193
P9	NC191	P9	NC191
P8	NC190	P8	NC190
P2	NC189	P2	NC189
P1	NC184	P1	NC184
N14	NC182	N14	NC182
N13	NC181	N13	NC181
N12	NC180	N12	NC180
N11	NC179	N11	NC179
N10	NC178	N10	NC178
N9	NC177	N9	NC177
N8	NC176	N8	NC176
N7	NC175	N7	NC175
N6	NC174	N6	NC174
N3	NC171	N3	NC171
N1	NC169	N1	NC169
M14	NC168	M14	NC168
M13	NC167	M13	NC167
M12	NC166	M12	NC166
M11	NC165	M11	NC165
M10	NC164	M10	NC164
M9	NC163	M9	NC163
M8	NC162	M8	NC162
M7	NC161	M7	NC161
M3	NC157	M3	NC157
M2	NC156	M2	NC156
M1	NC155	M1	NC155
L14	NC154	L14	NC154
L13	NC153	L13	NC153
L12	NC152	L12	NC152
L3	NC143	L3	NC143
L2	NC142	L2	NC142
L1	NC141	L1	NC141
K14	NC140	K14	NC140
K13	NC139	K13	NC139
K12	NC138	K12	NC138
K3	NC129	K3	NC129
K2	NC128	K2	NC128
K1	NC127	K1	NC127
J14	NC126	J14	NC126
J13	NC125	J13	NC125
J12	NC124	J12	NC124
J3	NC115	J3	NC115
J2	NC114	J2	NC114
J1	NC113	J1	NC113
H14	NC112	H14	NC112
H13	NC111	H13	NC111
H12	NC110	H12	NC110
H3	NC101	H3	NC101
H2	NC100	H2	NC100
H1	NC99	H1	NC99

KLMBG2JETD-B041
SDINBDA6-32G-XI1



Title: Flash-eMMC Flash	
File: ROC-3568-PC	REV: V0.1
Create Date: Thursday, May 07, 2020	Page Num: 28
Modify Date: Wednesday, May 19, 2021	Page Total: 45

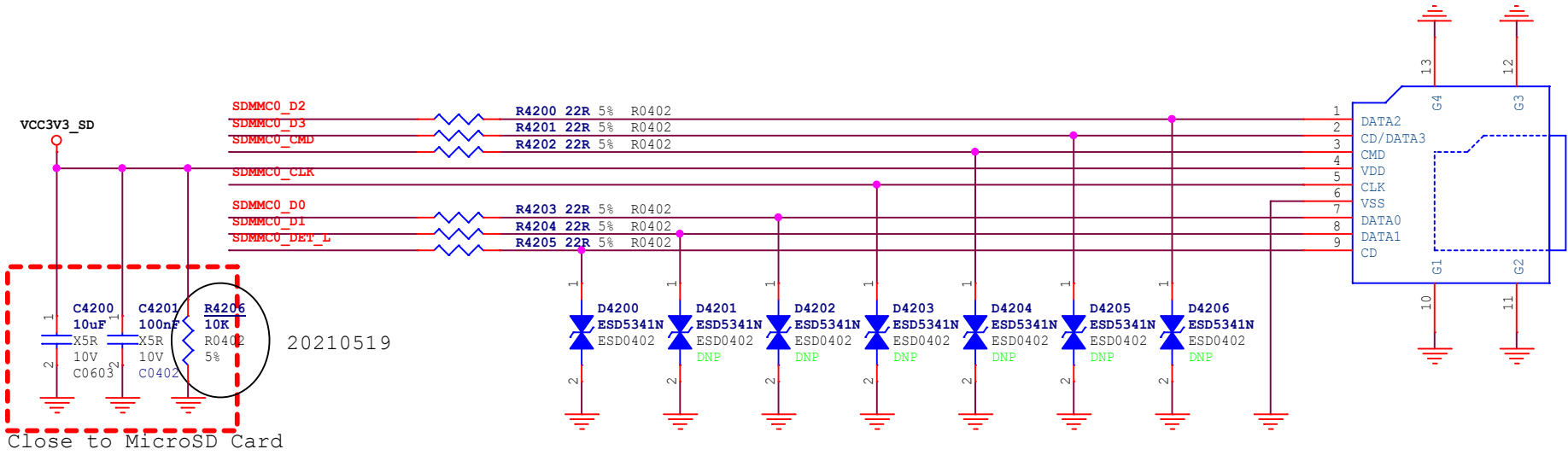
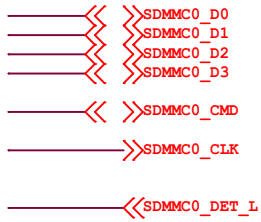

20210519

Close to MicroSD Card

MicroSD Card



Title: Flash-MicroSD Card	
File: ROC-3568-PC	REV: V0.1
Create Date: Thursday, May 07, 2020	Page Num: 29
Modify Date: Wednesday, May 19, 2021	Page Total: 45

>>FSPI_CLK/FLASH_ALE
 >>FSPI_D0/FLASH_RDY
 >>FSPI_D1/FLASH_RDn
 >>eMMC_RSTn/FSPI_D2/FLASH_WPn
 >>FSPI_D3/FLASH_CS1n
 >>FSPI_CS0n/FLASH_CS0n

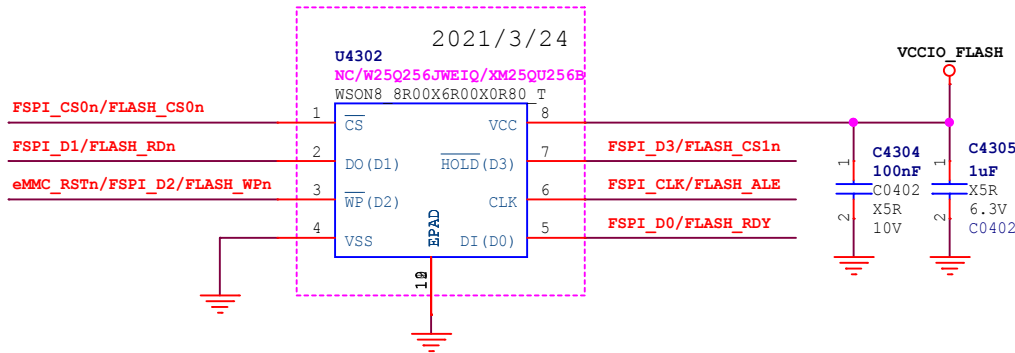

Default: 1.8V

SPI Nor: W25Q256JWEIQ 1.8V--DEFAULT
 W25Q256FV, GD25Q256D 3.3V

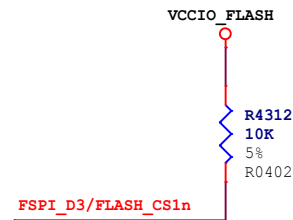
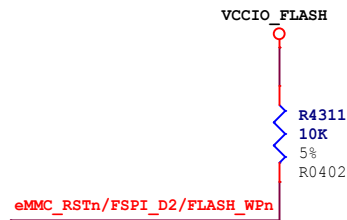
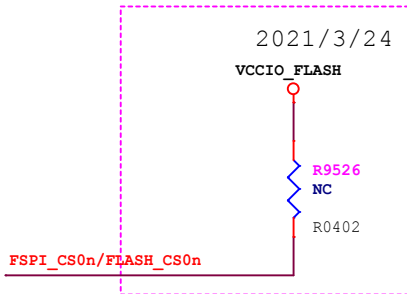



www.t-firefly.com

Title: Flash-SPI FLASH	
File: ROC-3568-PC	REV: V0.1
Create Date: Thursday, May 07, 2020	Page Num: 30
Modify Date: Wednesday, May 19, 2021	Page Total: 45

MIPI-CSI_RX CON

- >> MIPI_CSI_RX_D0P
- >> MIPI_CSI_RX_D0N
- >> MIPI_CSI_RX_D1P
- >> MIPI_CSI_RX_D1N
- >> MIPI_CSI_RX_D2P
- >> MIPI_CSI_RX_D2N
- >> MIPI_CSI_RX_D3P
- >> MIPI_CSI_RX_D3N
- >> MIPI_CSI_RX_CLKOP
- >> MIPI_CSI_RX_CLKON
- >> MIPI_CSI_RX_CLKIP
- >> MIPI_CSI_RX_CLKIN
- >> CIF_CLKOUT
- >> REFCLK_OUT_CAM
- >> I2C4_SDA_M0
- >> I2C4_SCL_M0
- >> CAMERA0_PDN_L_GPIO4_B4
- >> CAMERA1_PDN_L_GPIO4_B5
- >> CAM_RST_GPIO0_D5_1V8
- >> CAM1_RST_GPIO0_D6_1V8

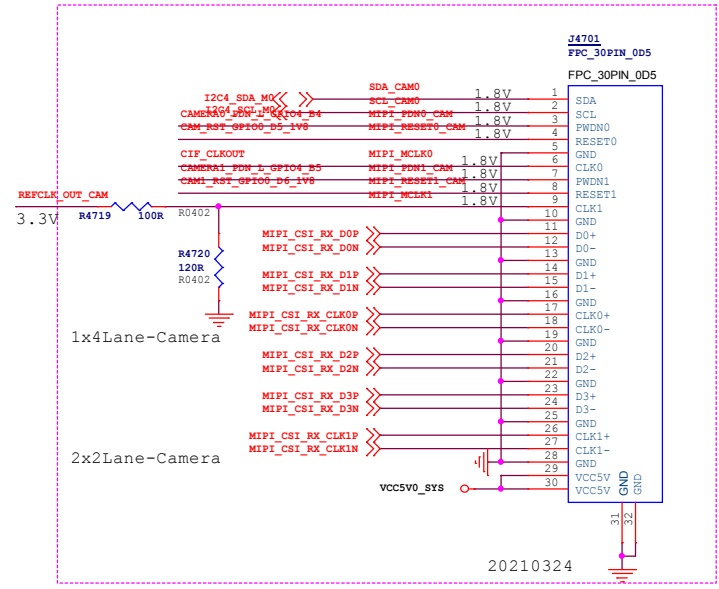

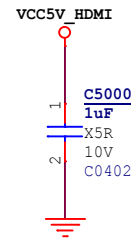
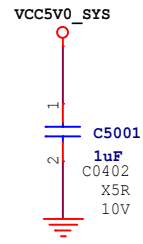

Rockchip Confidential

- >>HDMI_TX2P_PORT
- >>HDMI_TX2N_PORT
- >>HDMI_TX1P_PORT
- >>HDMI_TX1N_PORT
- >>HDMI_TX0P_PORT
- >>HDMI_TX0N_PORT
- >>HDMI_TXCLKP_PORT
- >>HDMI_TXCLKN_PORT
- <<HDMI_TX_SCL
- <<HDMI_TX_SDA
- <<HDMI_TX_CEC_M0
- <<HDMI_TX_HPDIN

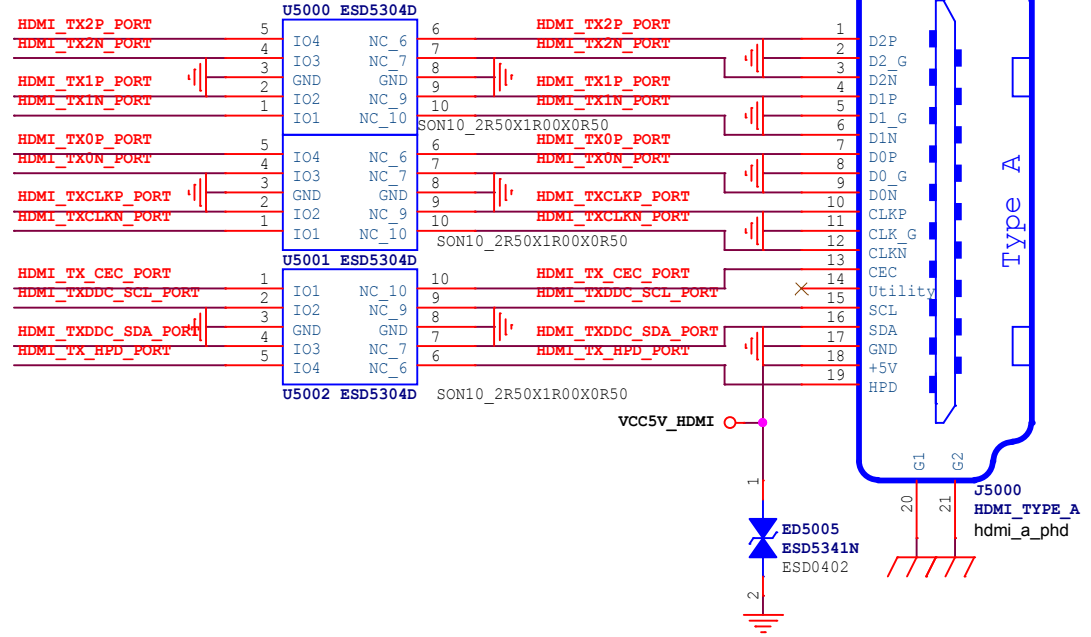
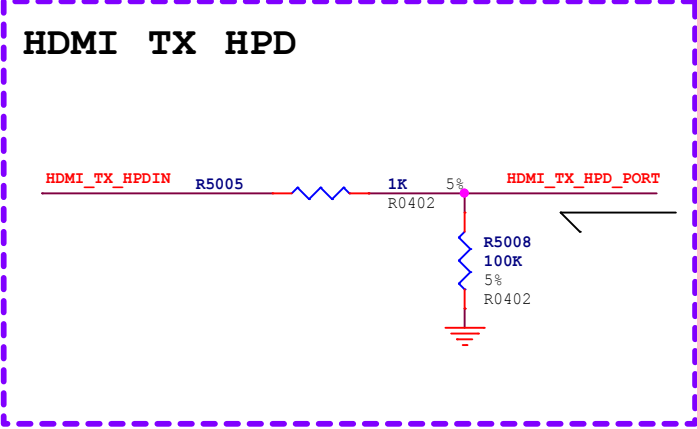
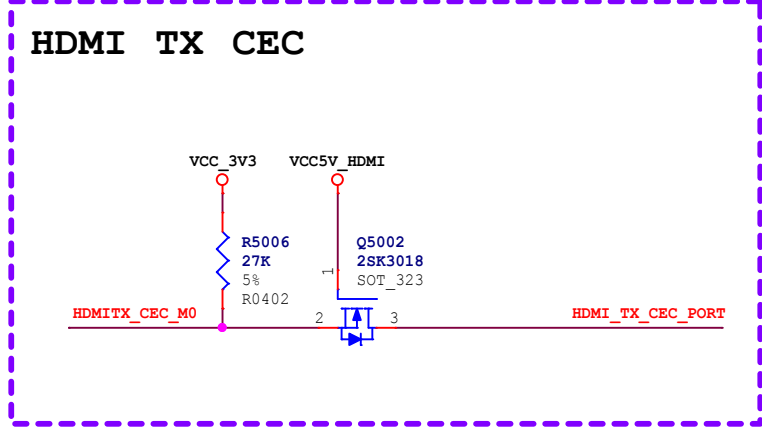
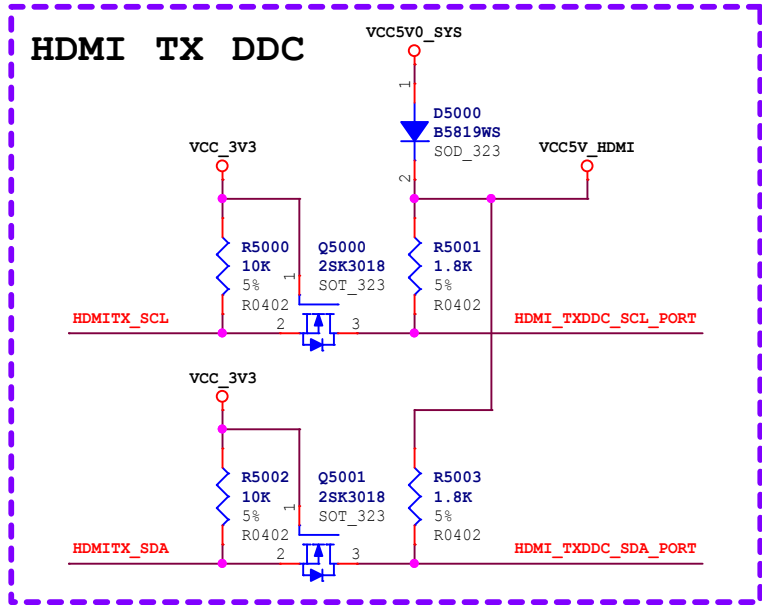

$C_j \leq 0.4 \text{ pF}$





www.t-firefly.com

Title: VO-HDMI2.0 TX		REV: V0.1
File: ROC-3568-PC		
Create Date: Thursday, May 07, 2020	Page Num: 32	
Modify Date: Wednesday, May 19, 2021	Page Total: 45	



>> MIPI_DSI_TX0_D0P/LVDS_TX0_D0P
 >> MIPI_DSI_TX0_D0N/LVDS_TX0_D0N
 >> MIPI_DSI_TX0_D1P/LVDS_TX0_D1P
 >> MIPI_DSI_TX0_D1N/LVDS_TX0_D1N
 >> MIPI_DSI_TX0_D2P/LVDS_TX0_D2P
 >> MIPI_DSI_TX0_D2N/LVDS_TX0_D2N
 >> MIPI_DSI_TX0_D3P/LVDS_TX0_D3P
 >> MIPI_DSI_TX0_D3N/LVDS_TX0_D3N
 >> MIPI_DSI_TX0_CLKP/LVDS_TX0_CLKP
 >> MIPI_DSI_TX0_CLKN/LVDS_TX0_CLKN

>> I2C1_SCL_TP
 << I2C1_SDA_TP
 >> TP_INT_L_GPIO0_B5
 >> TP_RST_L_GPIO0_B6

>> LCD0_BL_PWM4
 >> LCD0_PWREN_H_GPIO0_C7

<< BL_EN0_GPIO3_B0
 << LCD0_RST_GPIO3_B5

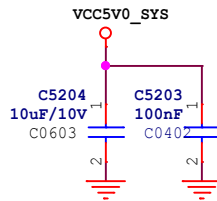
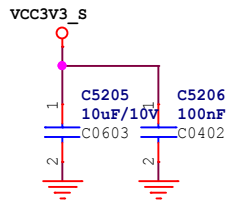
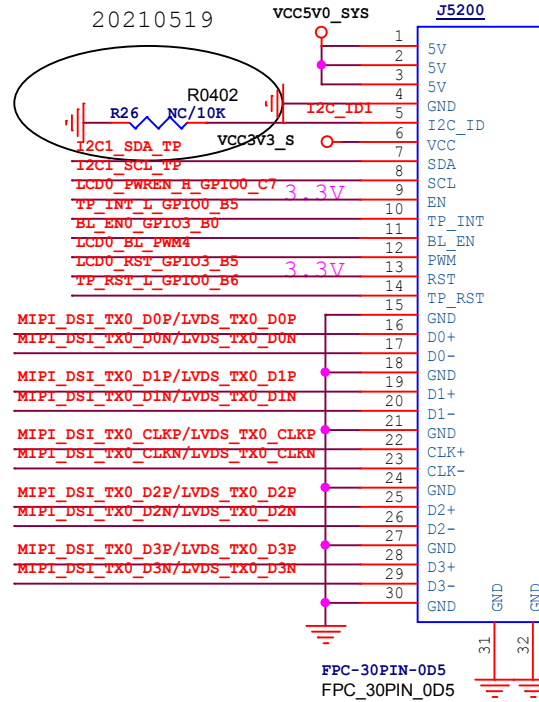
<< SARADC_VIN2_LCD_ID
 SARADC_VIN2_LCD_ID R5202 OR R0402 I2C_ID1



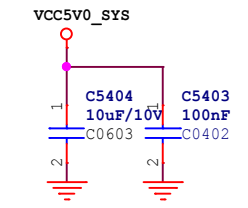
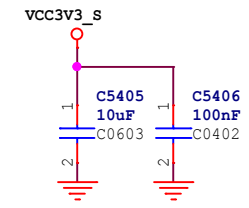
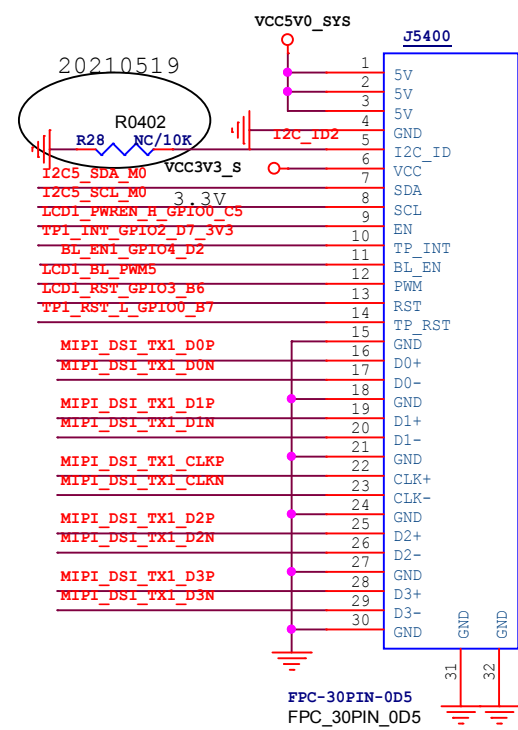
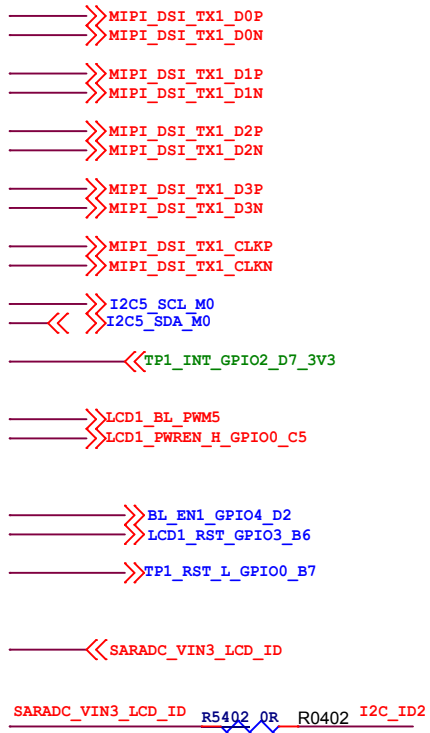

www.t-firefly.com
Title: VO-LCM MIPI-DSI TX0/LVDS TX0
File: ROC-3568-PC REV: V0.1
Create Date: Tuesday, May 19, 2020 Page Num: 33
Modify Date: Wednesday, May 19, 2021 Page Total: 45

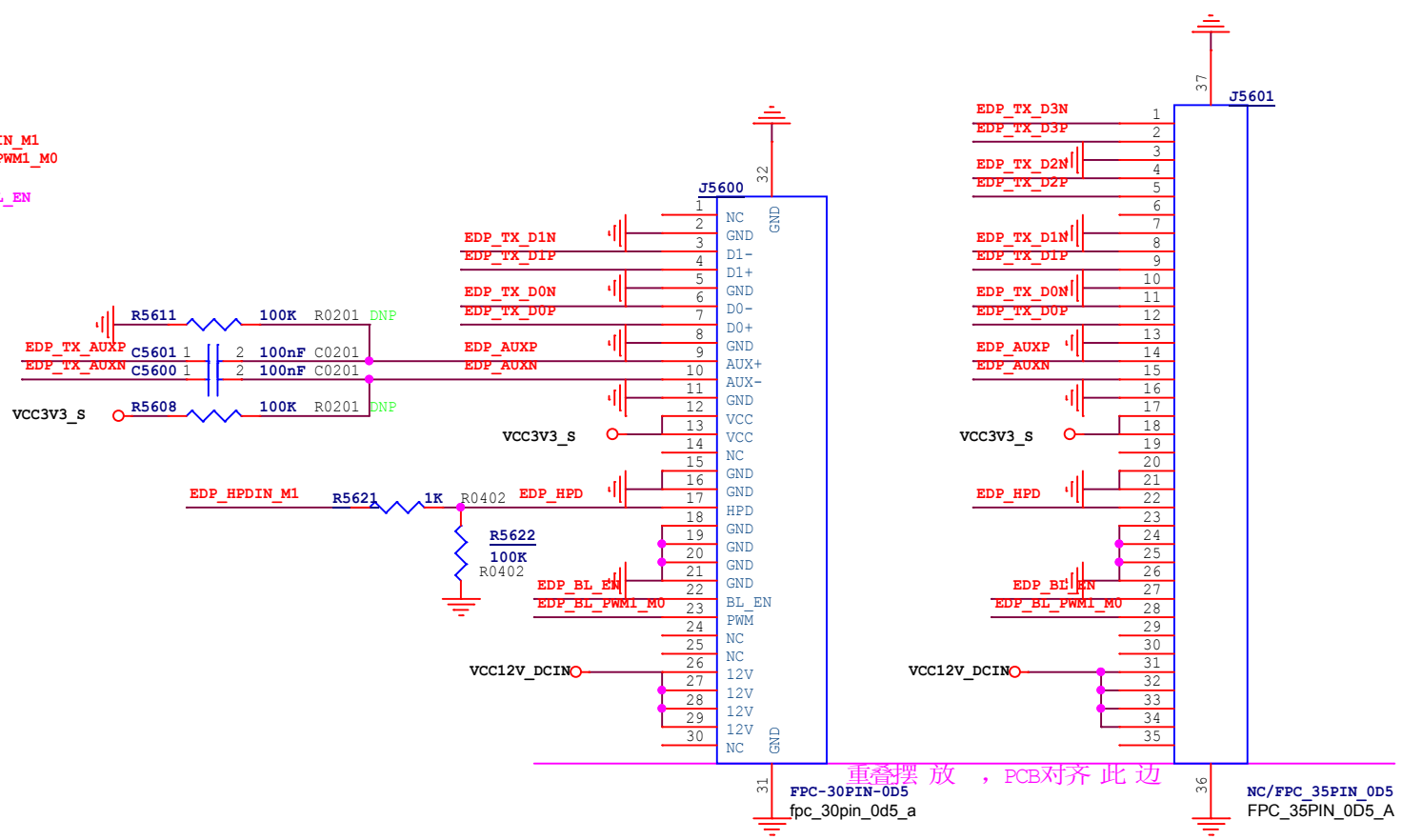

>>> EDP_TX_D0P
 >>> EDP_TX_D0N
 >>> EDP_TX_D1P
 >>> EDP_TX_D1N
 >>> EDP_TX_D2P
 >>> EDP_TX_D2N
 >>> EDP_TX_D3P
 >>> EDP_TX_D3N
 >>> EDP_TX_AUXP
 >>> EDP_TX_AUXN

<<< EDP_HPDIIN_M1
 <<< EDP_BL_PWM1_M0
 <<< EDP_BL_EN



重叠摆放，PCB对齐此边

Default no place, Support 4K eDP Panel

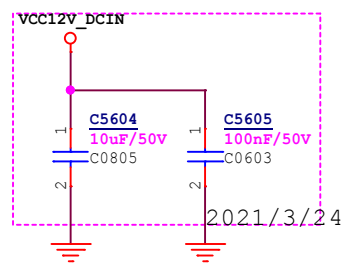
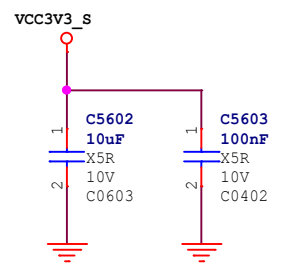

Title: VO-LCM eDP		REV: V0.1
File: ROC-3568-PC		
Create Date: Saturday, July 18, 2020	Page Num: 35	
Modify Date: Wednesday, May 19, 2021	Page Total: 45	

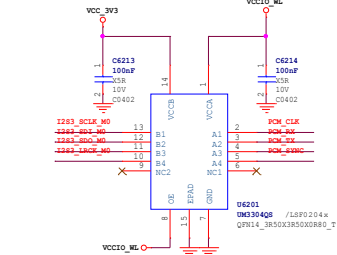
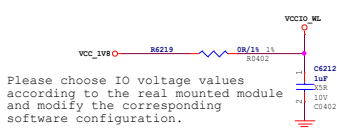
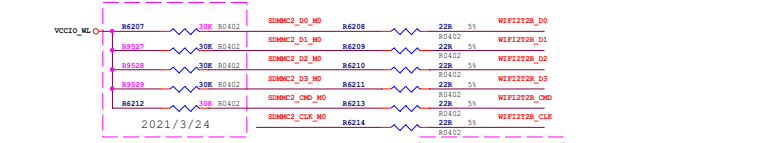
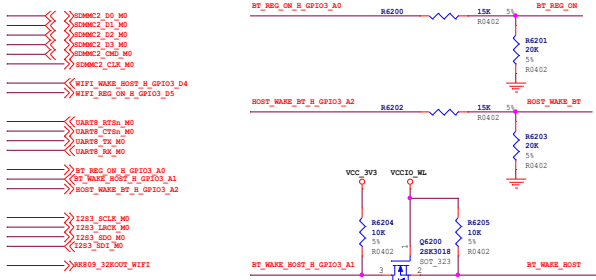

Rockchip Confidential

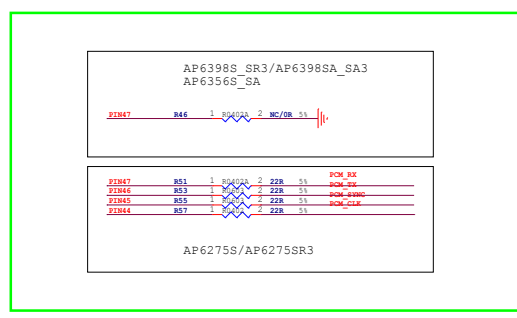
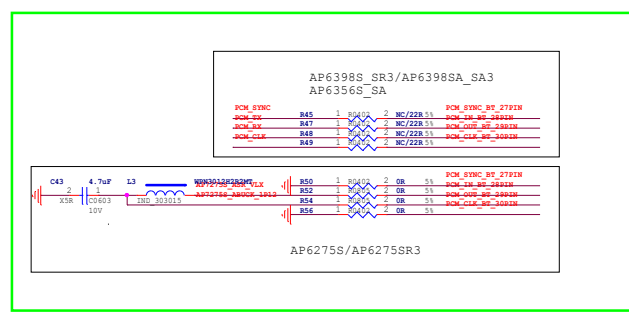
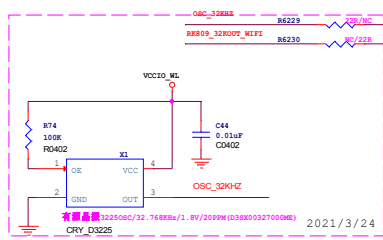
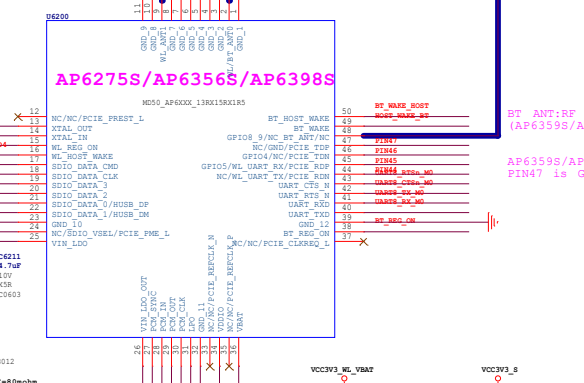
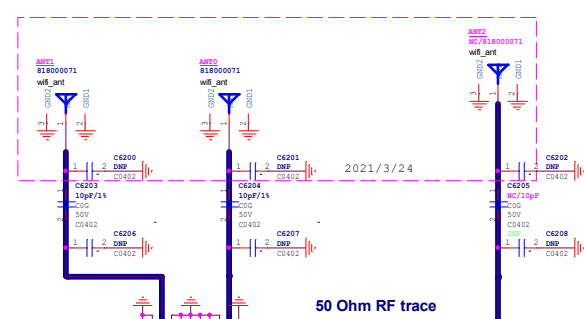
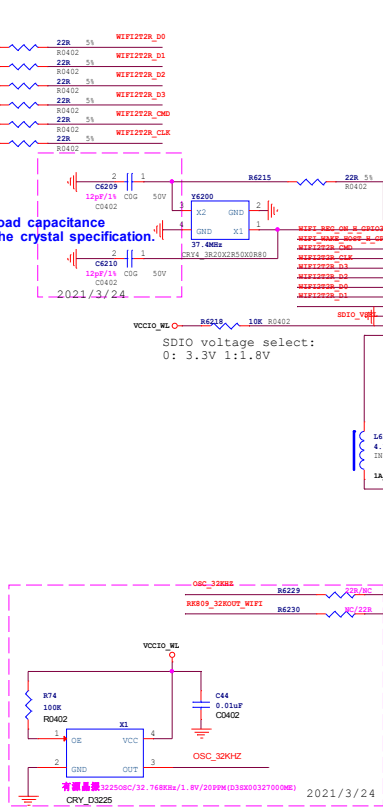

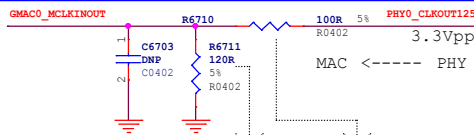
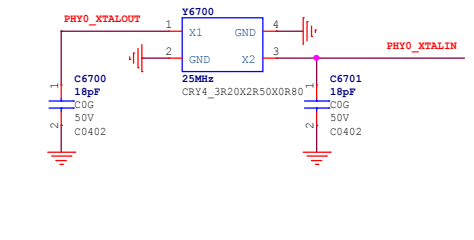
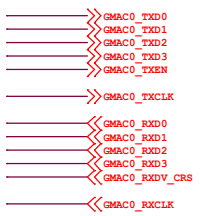

VCCIO_PHY0=3.3V	DNP	22R	Default
VCCIO_PHY0=1.8V	120R	100R	

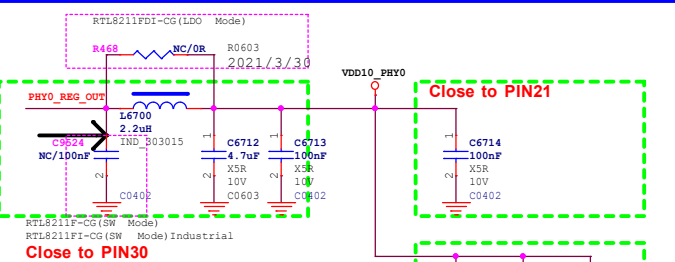
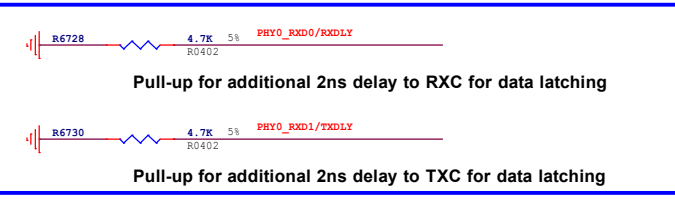
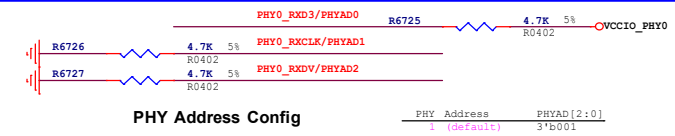
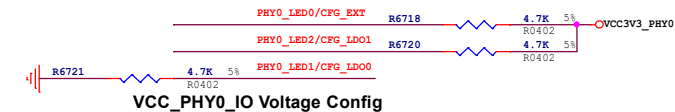
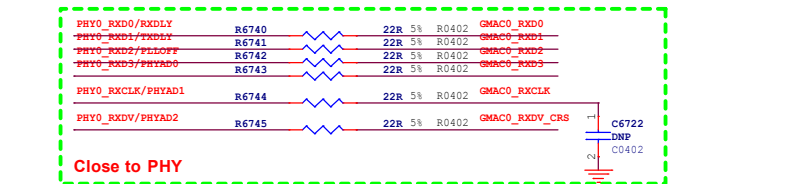
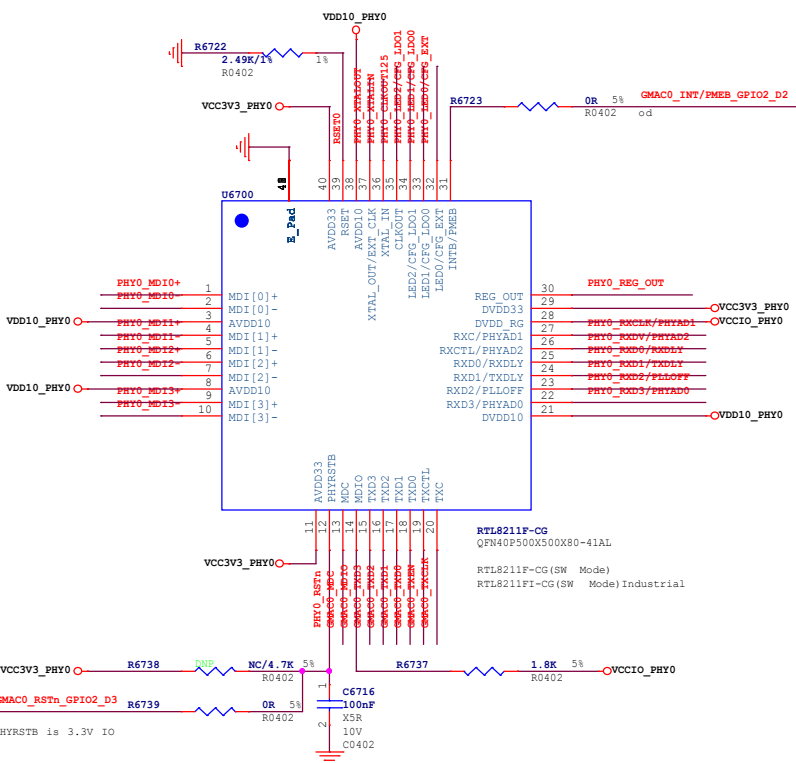
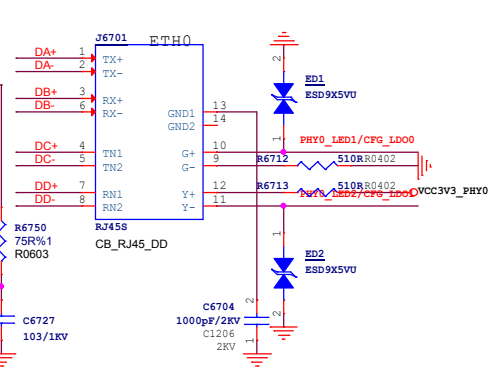
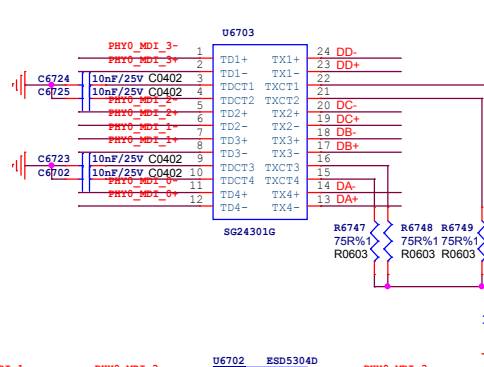
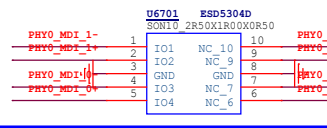
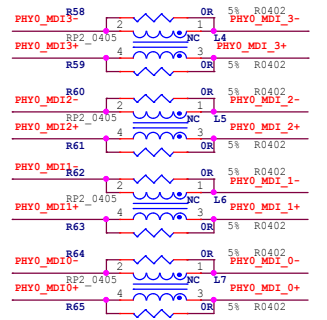

RGMI Power Source	CFG EXT	CFG LDO[1:0]
External 3.3V	1'b1	2'b00
External 1.8V (default)	1'b1	2'b10
Internal 1.8V	1'b0	2'b10

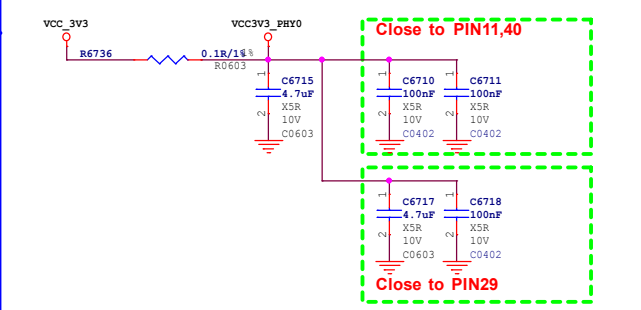
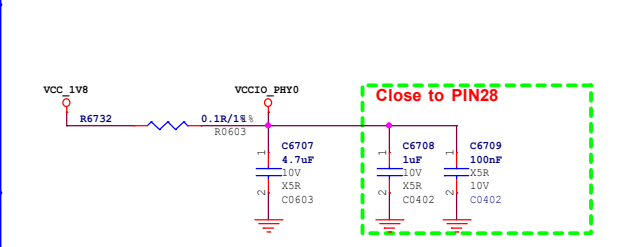
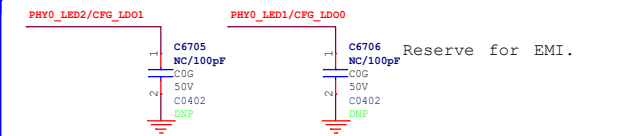

Title: Ethernet-GEPHY RGMII0	
File: ROC-3668-PC	REV: V0.1
Create Date: Tuesday, May 19, 2020	Page Num: 37
Modify Date: Wednesday, May 19, 2021	Page Total: 45

Rockchip Confidential

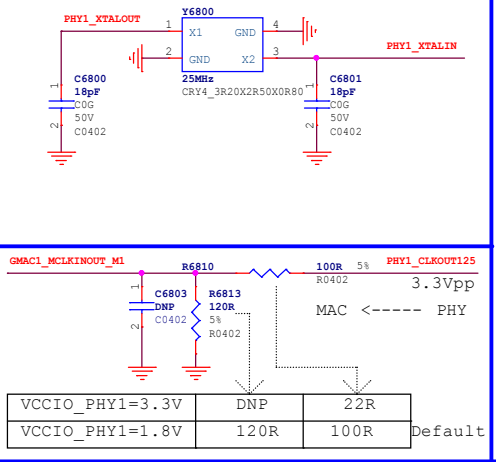
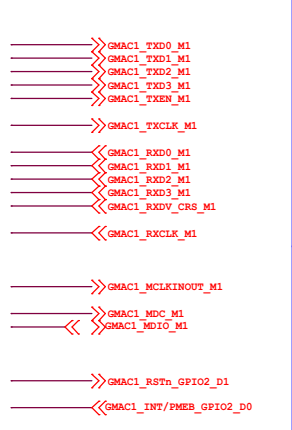

VCCIO_PHY1=3.3V	DNP	22R	Default
VCCIO_PHY1=1.8V	120R	100R	

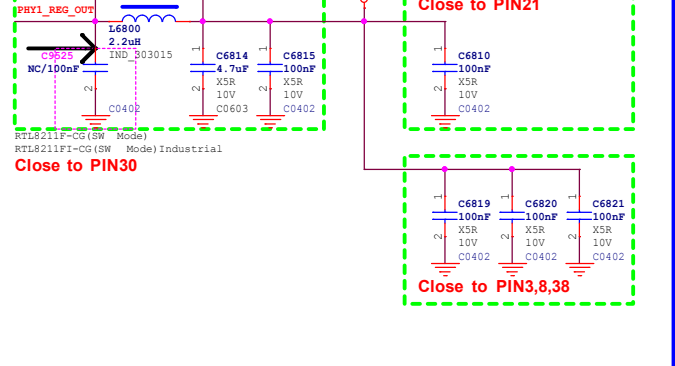
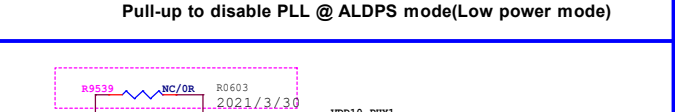
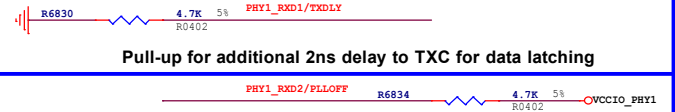
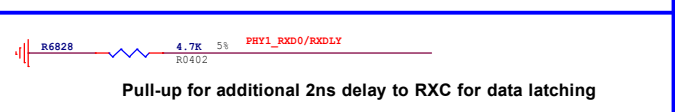
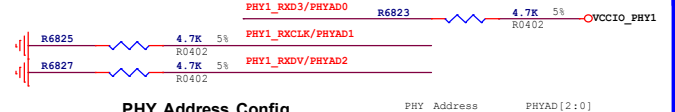
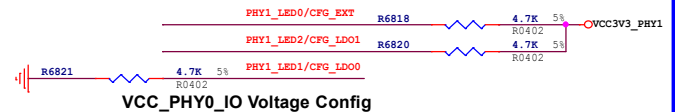
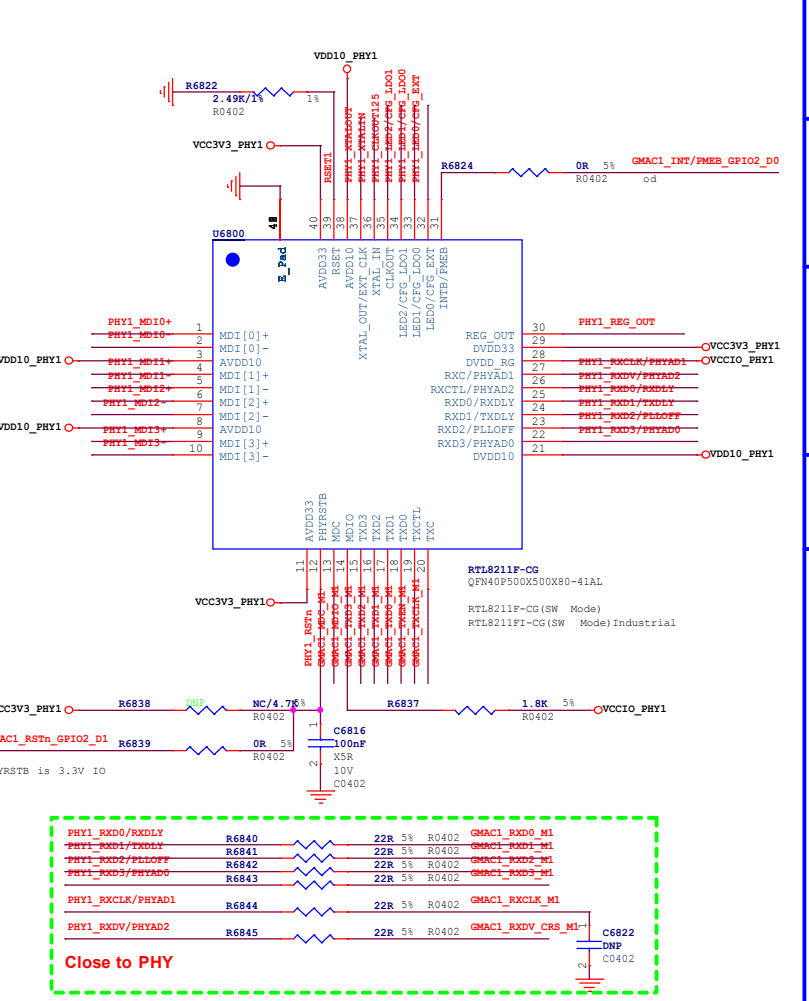
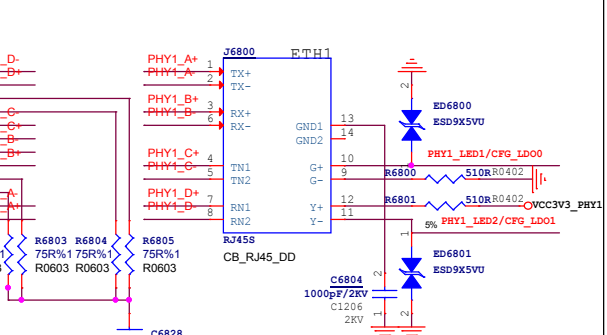
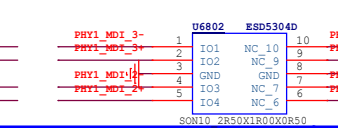
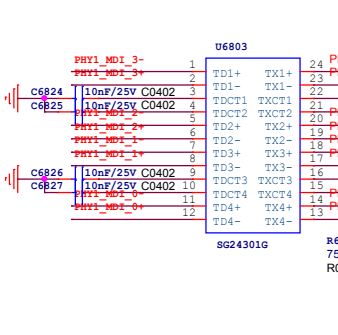
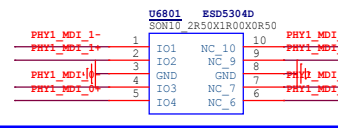
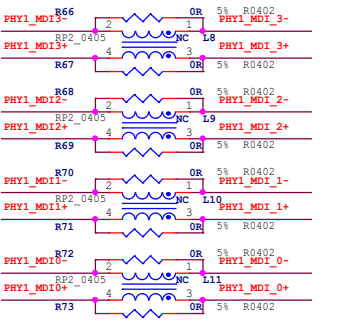

RGMII Power Source	CFG EXT	CFG LDO[1:0]
External 3.3V	1'b1	2'b00
External 1.8V (default)	1'b1	2'b10
Internal 1.8V	1'b0	2'b10

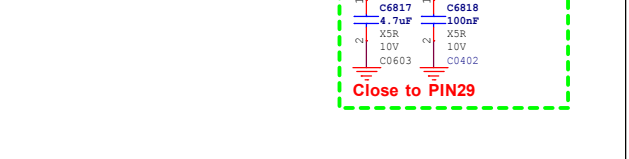
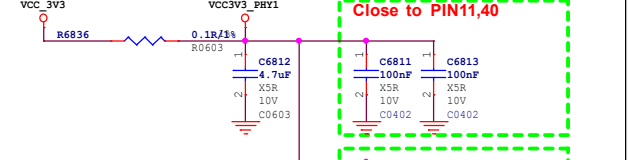
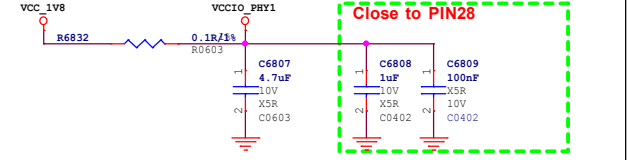
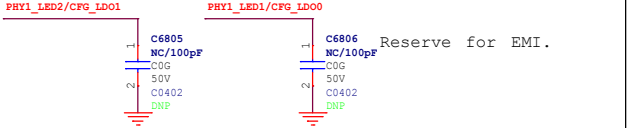

Title: Ethernet-GEPHY RGMII1	
File: ROC-3568-PC	REV: V0.1
Create Date: Tuesday, May 19, 2020	Page Num: 38
Modify Date: Wednesday, May 19, 2021	Page Total: 45

Headphone

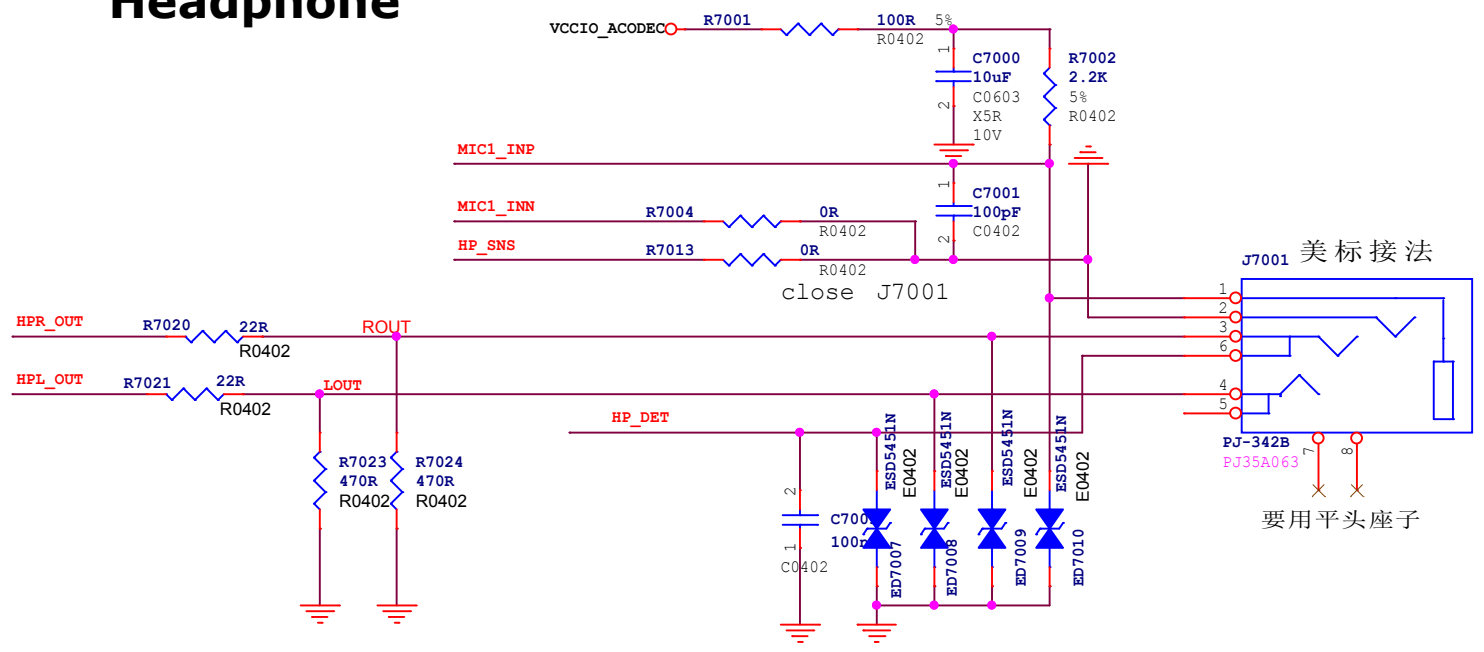
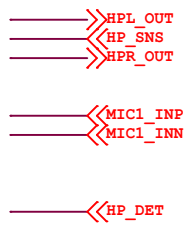

Title: Audio Port		REV: V0.1
File: ROC-3568-PC		
Create Date: Tuesday, May 19, 2020	Page Num: 39	
Modify Date: Wednesday, May 19, 2021	Page Total: 45	

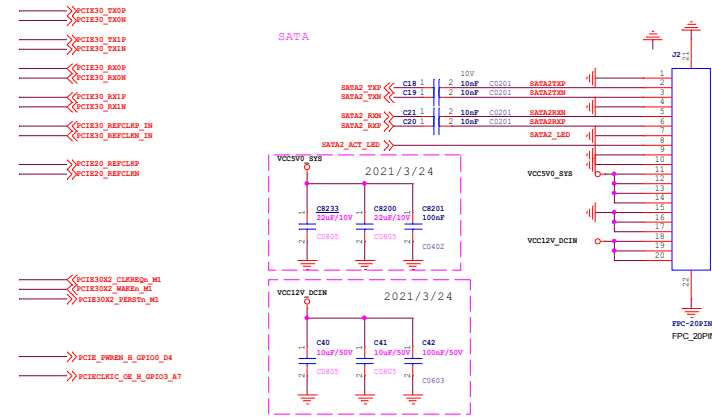

PCIe3.0 x 2Lanes (X 4Slot)

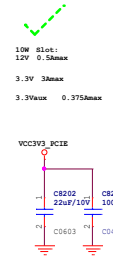
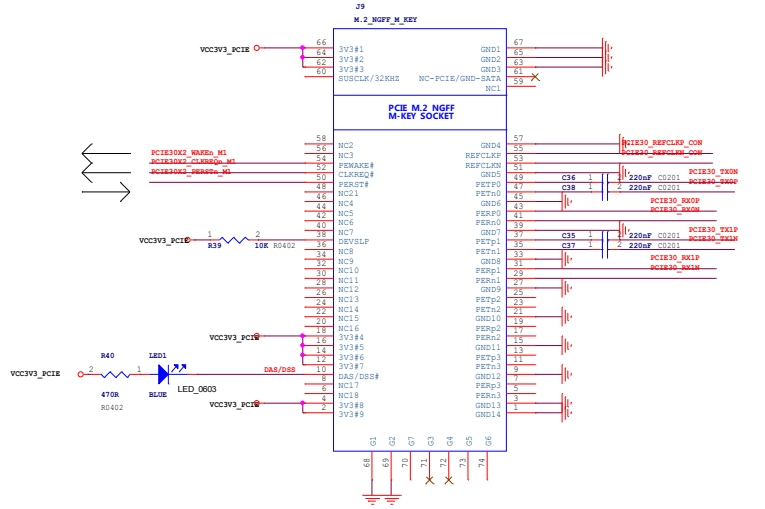

10W Slot:
12V 0.5Amax
3.3V 3Amax
3.3Vaux 0.375Amax

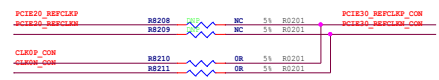

PIC6_S1	PIC6_S0	Out Freq
0	1	100MHz

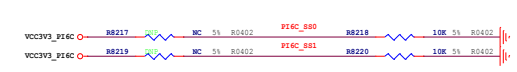

PIC6_SS1	PIC6_SS0	Spread %
0	0	No Spread
0	1	-0.5
1	0	-1.0
1	1	No Spread

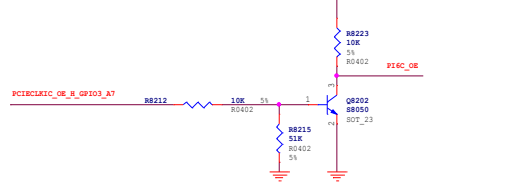
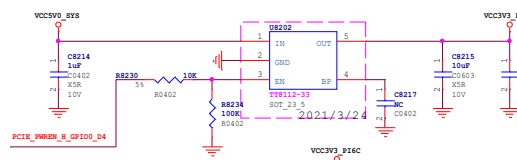

If board target trace impedance is 50ohm
then R = 475ohm providing a IREF of 2.32 mA .
The output current (IOH) is 6 * IREF .
6x2.32x50=696mV

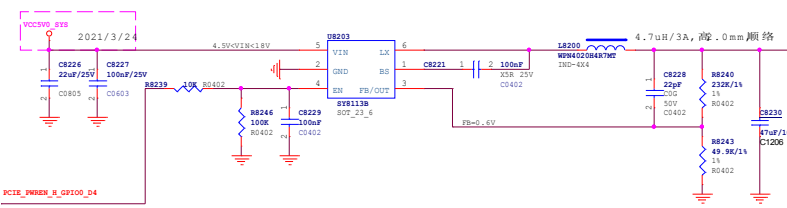

I2C5_SCL_M0
 I2C5_SDA_M0
 GSENSOR_INT_L_GPIO3_C1

Gyroscope+G-sensor

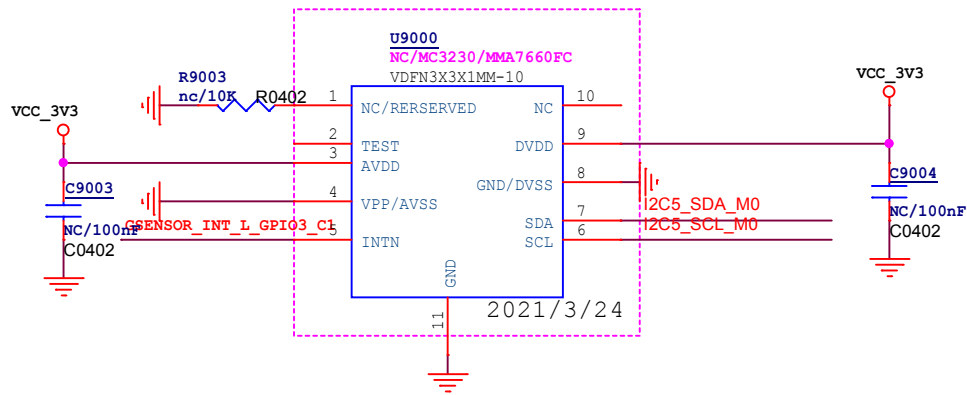

Title: Sensor		REV: V0.1
File: ROC-3568-PC		
Create Date: Tuesday, May 19, 2020	Page Num: 41	
Modify Date: Wednesday, May 19, 2021	Page Total: 45	

- UART3_RX_M1
- UART3_TX_M1
- UART2_TX_M0_DEBUG
- UART2_RX_M0_DEBUG
- UART4_TX_M1
- UART4_RX_M1
- DIY1_LED_GPIO1_B0
- DIY2_LED_GPIO2_C1

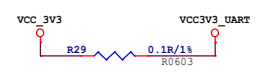

UART3_M1

UART2_DEBUG

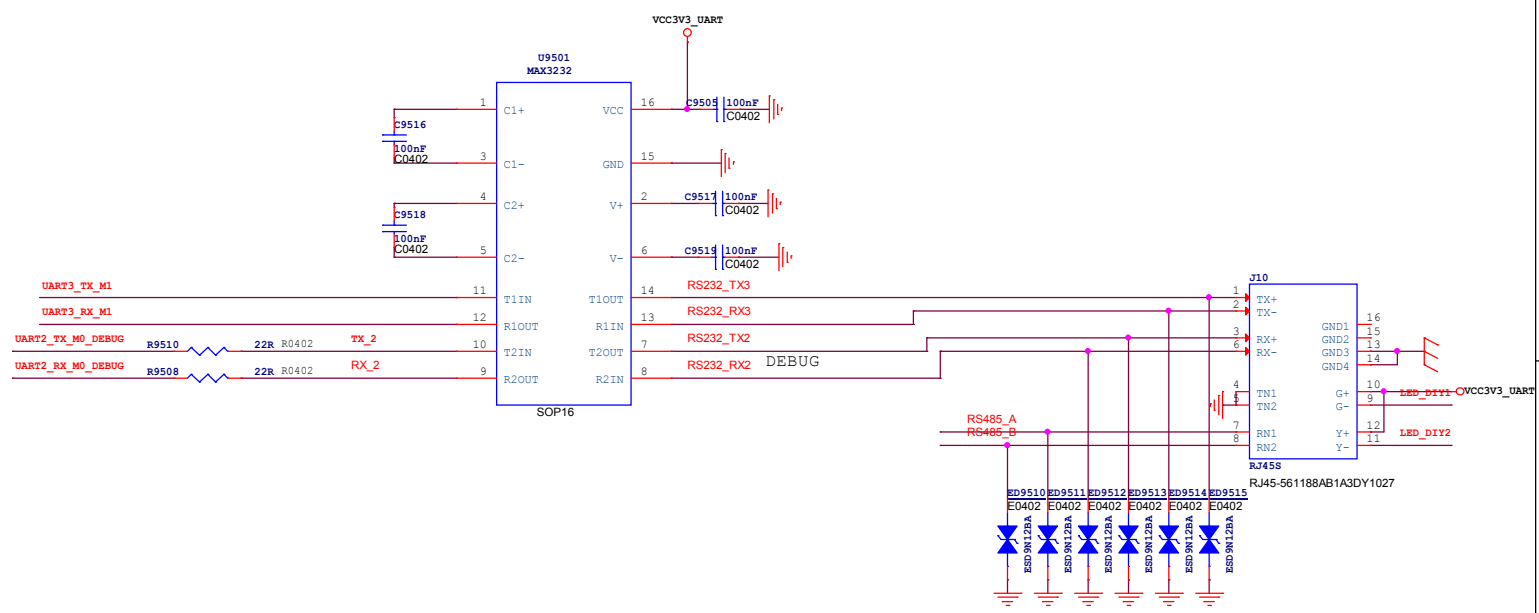

RS485

UART4_M1

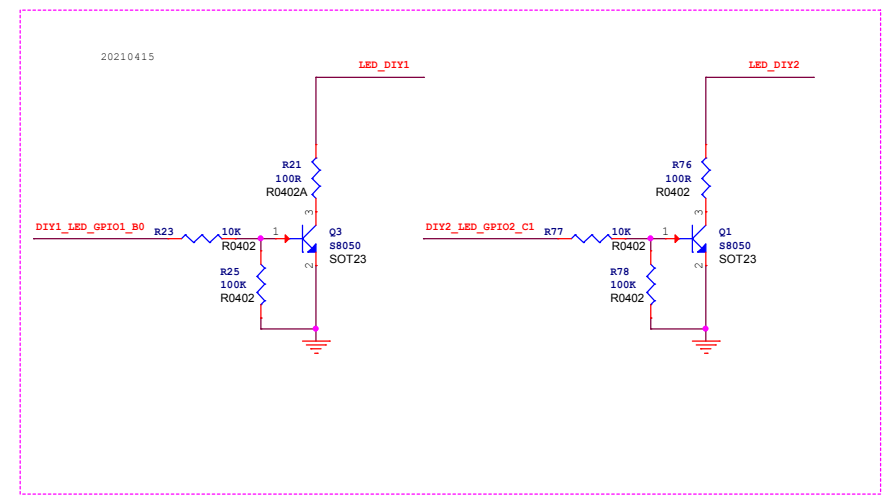
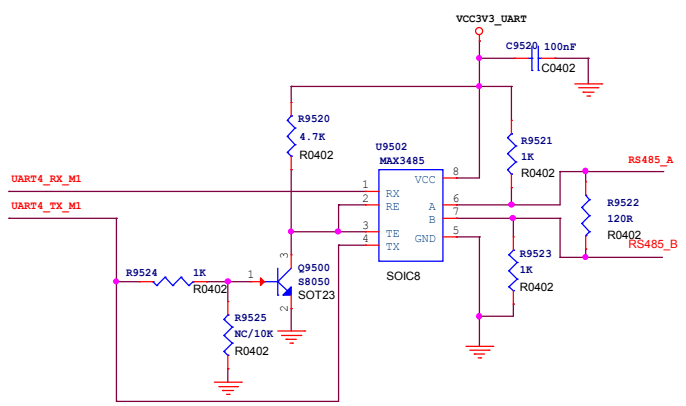



www.t-firefly.com

Title: RS232/RS485		REV: V0.1
File: ROC-3568-PC		
Create Date: Friday, July 10, 2020	Page Num: 42	
Modify Date: Wednesday, May 19, 2021	Page Total: 45	

2021/4/08

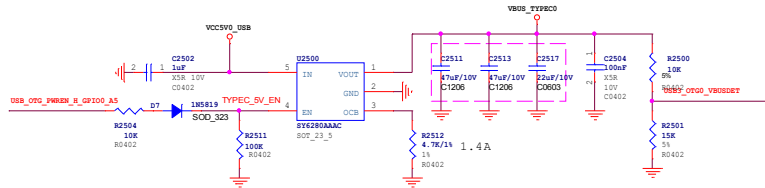
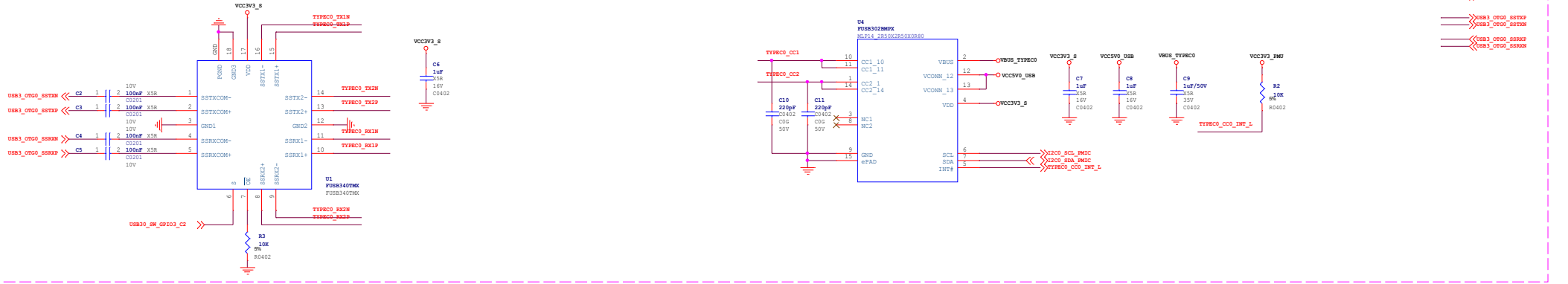

2021/4/08

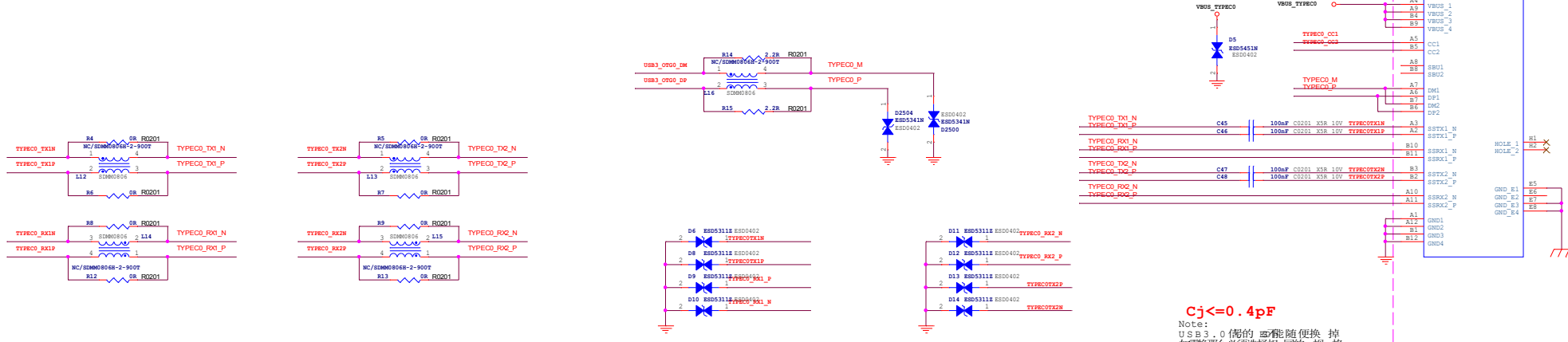

Cj<=0.4pF
 Note:
 USB3.0 偏置的 电容 随便换 掉
 如 需 精 确 必 须 选 择 相 同 的 规 格。

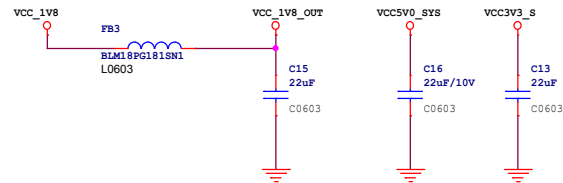
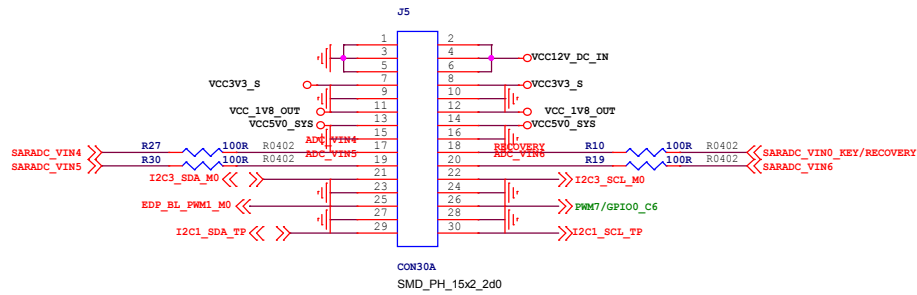

SPK

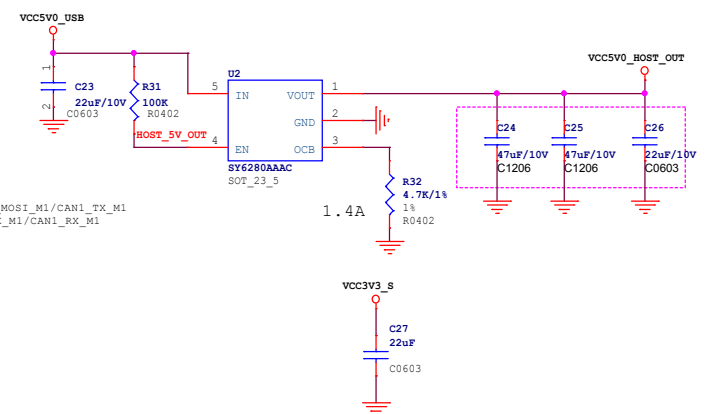
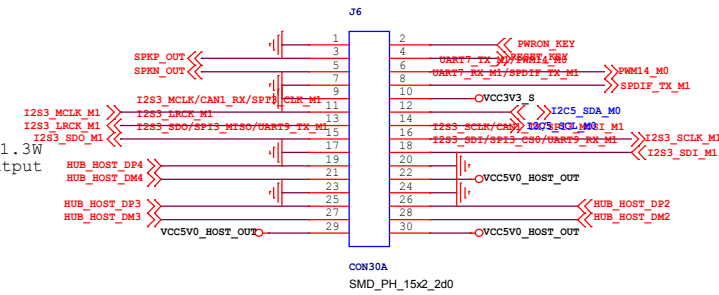

Note: 8ohm/1.3W
Speaker Output



CAN1_M1

www.t-firefly.com

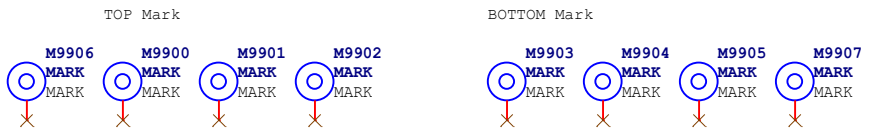
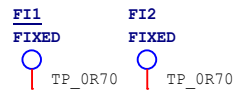
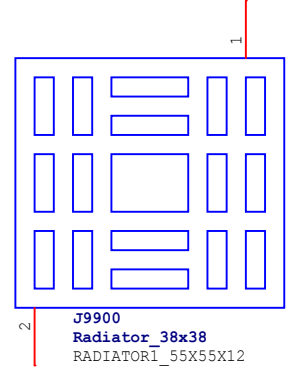
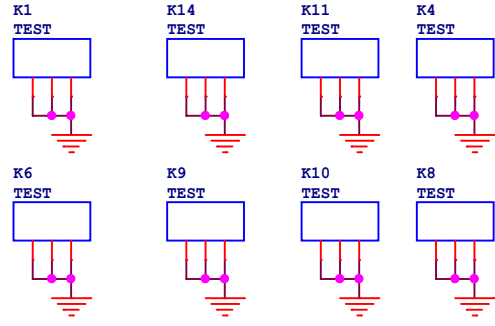
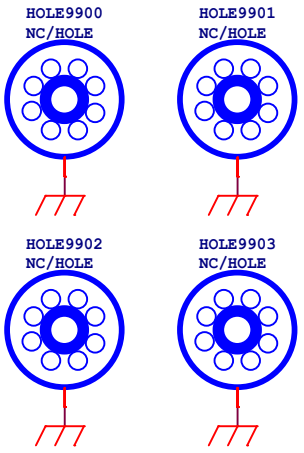
Title: Extension Interface		REV: V0.1
File: ROC-3399-PC+		
Create Date: Thursday, November 05, 2020	Page Num: 44	
Modify Date: Wednesday, May 19, 2021	Page Total: 45	

www.t-firefly.com

Title: Mark/Hole/Heatsink

File: ROC-3568-PC REV: V0.1

Create Date: Tuesday, May 19, 2020 Page Num: 45

Modify Date: Wednesday, May 19, 2021 Page Total: 45